

GIGALIGHT100GBASE-LR4 CFP 10kmOptical Transceiver P/N: GCF-S101-LR4C

Features

- ◆ Operating optical data rate up to 112Gbps
- ◆ Transmission distance up to 10km
- ◆ CFP MSA compliant
- ◆ Compliant to 100GbE IEEE 802.3ba specification for 100GBASE-LR4 links
- ◆ OTU4 compatible
- ◆ 1310 nm window cooled EA-DFB LD and PIN ROSA
- ◆ 10 parallel electrical serial interface and AC coupling of CML signals
- ◆ Hot pluggable electrical interface
- ◆ Low power dissipation<9W
- ◆ Operating case temperature 0°C to +70°C
- ◆ Single 3.3V power supply
- ◆ RoHS 6 compliant(lead free)



Applications

- ◆ 100GbE IEEE 802.3ba 100GBASE-LR4
- ◆ OTN-OTU4
- ◆ Switch to switch interface or Switch to router interface

Description

The Gigalight 100GBASE-LR4 CFP module is the CFP optical transceiver which is a hot pluggable form factor designed for high speed optical networking application. The module is designed for 100Gigabit Ethernet application and provides 100GBASE-LR4 compliant optical interface, CAUI electrical interface and MDIO module management interface. The module converts 10-lane 10.3Gb/s electrical data streams to 4-lane LAN-WDM25.78Gb/s optical output signal and 4-lane LAN-WDM25.78Gb/s optical input signal to 10-lane 10.3Gb/s electrical data streams. This 10-lane 10.3Gb/s electrical signal is fully compliant with 802.3ba CAUI specification and allows FR4 host PCB trace up to 25cm. The high performance Cooled LAN-WDM EML transmitter and high sensitivity PIN receiver provide superior performance for 100Gigabit Ethernet applications up to 10km links and compliant optical interface with IEEE802.3ba Clause 88

100GBASE-LR4 requirements.

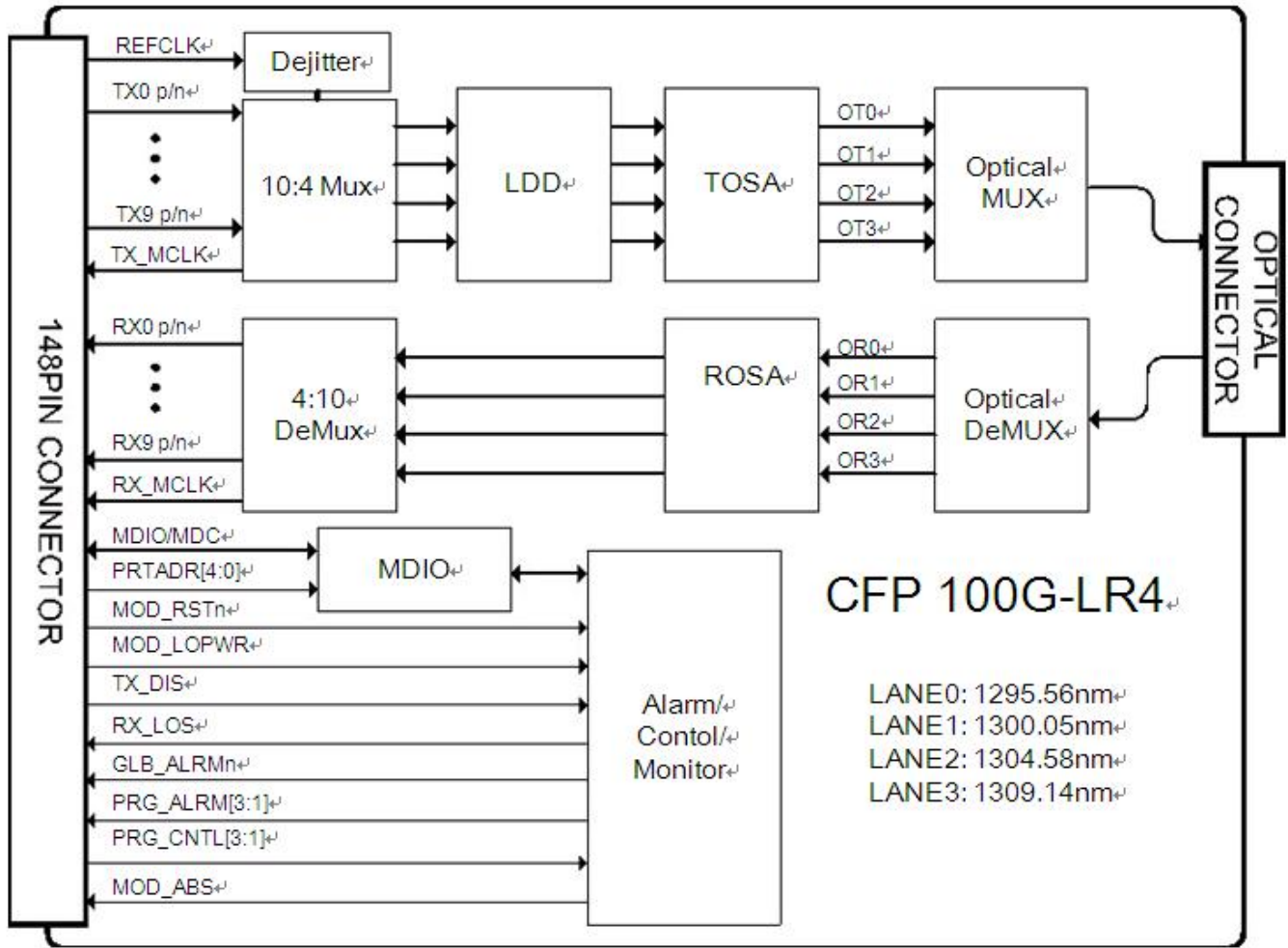

Module Block Diagram

Absolute Maximum Ratings

Parameter	Symbol	Unit	Min	Max
Storage Temperature Range	Ts	°C	-40	+85
Relative Humidity	RH	%	5	85
Power Supply Voltage	Vcc	V	-0.5	+ 3.6
Operating Case Temperature Range	Tc	°C	-5	75
Receiver Damage Threshold Per Lane	Pdag	dBm	+5.5	

Recommended Operating Conditions

Parameter	Symbol	Unit	Min	Typ	Max
Operating Case Temperature Range	Tc	°C	0		70
Power Supply Voltage	Vcc	V	3.2	3.3	3.4
Data rate		Gb/s		103.125	112

Products Characteristics(tested under recommended operating conditions)

Parameter	Symbol	Unit	Min	Typ	Max	Notes
Voltage Supply Electrical Characteristics						
Supply Current Tx Section / Rx Section		A	-	-	3	1
Power Supply Noise	Vrip				2%	DC-1MHz
					3%	1-10MHz
Dissipation Class2	Pw	W			9	
Low Power Dissipation	Plow	W			2	
Inrush Current I_{n2}	I-inrush mA/usec				50	
Turn-off Current I_{Class2}	I-turnoff mA/usec		-50			
Different Signal Electrical Characteristics						
Single Ended Data Input Swing		mV	55 -		525	
Single Ended Data Output Swing		mV	180 -		385	
Differential Signal Resistance	Output	Ω	80		120	
Differential Signal Resistance	Input	Ω	80		120	
3.3V LVCMOS Electrical Characteristics						
Input High Voltage	3.3VIH	V	2.0		Vcc+0.3	
Input Low Voltage	3.3VIL	V	-0.3 -		0.8	
Input Leakage Current	3.3IIN	μ A	-10		+ 10	
Output HighVoltage($I_{OH}=100\mu$ A)	3.3VOH	V	Vcc-0.2 -		-	
Output Low Voltage ($I_{OI} = 100\mu$ A)	3.3VOL	V			0.2	
Minimum Pulse Width of Control Pin Signal	T_CNTL	us	100			
1.2V LVCMOS Electrical Characteristics						
Input High Voltage	1.2VIH	V	0.84		1.5	
Input Low Voltage	1.2VIL	V	-0.3		0.36	
Input Leakage Current	1.2IIN	μ A	-100		+ 100	
Output HighVoltage	1.2VOH	V	1.0		1.5	

Output Low Voltage	1.2VOL	V	-0.3		0.2	
Output High Current	1.2IOH	mA			-4	
Output Low Current	1.2IOL	mA	+4			
Input Capacitance	Ci	pF			10	
Optical Transmitter Characteristics						
Signaling Rate for Each Lane (100GbE)		Gbps	-	25.78125+/-	100ppm	
Signaling Rate for Each Lane (OTU4)			27.95249+/-	20ppm		
Four Lane Wavelength Range	λ1	nm	1294.53	1295.56	1296.59	
	λ2		1299.02	1300.05	1301.09	
	λ3		1303.54	1304.58	1305.63	
	λ4		1308.09	1309.14	1310.19	
Side Mode Suppression Ratio	SMSR	dB	30		-	
Total Average Launch Power (100GbE)			-		10.5	
Total Average Launch Power(OTU4)	Pt	dBm			8.9	
Average Launch Power for Each Lane(100GbE)	Pa	dBm	-4.3		+4.5	2
Average Launch Power for Each Lane(OTU4)			-2.5		+2.9	
Optical Modulation Amplitude for Each Lane	OMA	dBm	-1.3		4.5	3
Transmitter and Dispersion Penalty for Each Lanes(100GbE)		TDP			2.2	
Transmitter and Dispersion Penalty for Each Lanes(OTU4)		TDP			1.5	
Average Launch Power of Off Transmitter for Each Lanes	Poff	dBm	-		-30	
Extinction Ratio (100GbE)	EX	dB	4			
Extinction Ratio (OTU4)			7			

Maximum channel power difference		dB			5	
RIN20OMA		dB/Hz			-130	
Optical Return Loss Tolerance		dB			20	
Transmitter Reflectance		dB			-12	4
Eye Diagram		Compliant with IEEE 802.3ba-2010/G.959.1)				
Optical Receiver Characteristics						
Receive Rate for Each Lane(100GbE)		Gbps		25.78125+/-		
Receive Rate for EachLane(OTU4)				100ppm		
Four Lane Wavelength Range	λ_1	nm	1294.53	1295.56	1296.59	
	λ_2		1299.02	1300.05	1301.09	
	λ_3		1303.54	1304.58	1305.63	
	λ_4		1308.09	1309.14	1310.19	
Overload Input Optical Power	Pmax	dBm	4.5			5
Total Input Optical Power(OTU4)	Pt	dBm			8.9	
Average Receive Power for Each Lane(100GbE)	Pin	dBm	-10.6		4.5	6&7
Average Receive Power for Each Lane(OTU4)			-8.8		2.9	
Receive Power In OMA for Each Lane	PinOMA	dBm	-		4.5	
Difference in Receive Power between Any Two		dBm	-		5.5	
Receiver Sensitivity in OMA for Each	Pmin	dBm			-8.6	8
Receiver Sensitivity for Each Lane(OTU4)					-10.3	9
StressedReceiver Sensitivity in OMA for Each		dBm			-6.8	10&11
Los Assert		dBm	-20		-15	

Los De-assert		dBm			-14	
Los Hysteresis		dBm	0.5			
Chromatic Dispersion		Ps/nm	-28.5		+9.5	
Maximum reflectance of optical network element		dB			-26	
Delay Group differential		ps			8	

Note1. The supply current includes CFP module's supply current and test board working current.

Note2. Average launch power ,each lane(min) is informative and not the principal indicator of signal strength. A transmitter with launch power below this value cannot be compliant; however, a value above this does not ensure compliance

Note3. Even if the TDP<1dB, the OMA(min) must exceed this value

Note4. Transmitter reflectance is defined looking into the transmitter

Note5. The receiver shall be able to tolerate , without damage, continuous exposure to an optical input signal having this average power level

Note6. The average receive power , each lane (max) for 100GBASE-ER4 is larger than the 100BASE-ER4 transmitter value to allow compatibility with 100BASE-LR4 units at short distances

Note7. Average receive power, each lane (min) is informative and not the principal indicator of signal strength. A received power below this value cannot be compliant; however, a value above this does not ensure compliance

Note8. Receiver sensitivity (OMA), each lane (max) is informative

Note9. Measured with PRBS 231-1 for BER=10⁻⁵. The BER for the OTU4 application is required to be met only after FEC has been applied.

Note10. Measured with conformance test signal at TP3 for BER=10⁻¹² Note11. conditions of stressed receiver sensitivity test: vertical eye closure penalty for each lane is 1.8dB;stressed eye J2 jitter for each lane is 0.3UI; stressed eye J9 jitter for each lane is 0.47UI.

Hardware Control Pins

The CFP Module support real-time control functions via hardware pins, listed in the following table: Hardware Control Pins

Pin#	Symbol	Description	I/O	Logic	H	L	Pull-up/down
30	PRG_CNTL1	Programmable Control 1 MSADefault: TRXIC_RST n , TX&RX ICs reset, "0 " :reset; "1"	I	3.3V LVCMOS	per CFP MSA Management Interface Specification		Pull-Up Note1
31	PRG_CNTL2	Programmable Control 2 MSADefault : Hardware Interlock LSB	I	3.3V LVCMOS			Pull-Up Note1
32	PRG_CNTL3	Programmable Control 3 MSA Default:Hardware Interlock MSB	I	3.3V LVCMOS			Pull-Up Note1
36	TX_DIS	Transmitter Disable	I	3.3V LVCMOS	Disable	Enable	Pull-Up Note1
37	MOD_LOPW R	Module Low Power Mode	I	3.3V LVCMOS	Low Power	Enable	Pull-Up Note1
39	MOD_RSTn	Module Reset(Invert)	I	3.3V LVCMOS	Enable	Reset	Pull-Down Note2

Hardware Alarm Pins

The CFP Module supports alarm hardware pins listed in the following table: Hardware Alarm Pins

Pin#	Symbol	Description	I/O	Logic	H	L	Pull-up/down
33	prg_alm1	Programmable Alarm 1 MSADefault:HIPWR_ON	O	3.3V LVCMOS	Active High per MDIO document		
34	PRG ALRM 2	Programmable Alarm 2MSA default:MOD_READY , Ready State has been reached	O	3.3V LVCMOS			
35	PRG ALRM3	Programmable Alarm 3 MSA Default: MOD FAULT	O	3.3V LVCMOS			
38	MOD_ABS	Module Absent	O	3.3V LVCMOS	Absent	Present	Pull-Down Note1

40	RX_LOS	Receiver Loss of Signal	O	3.3V LVCMOS	Loss of Signal	OK	
----	--------	-------------------------	---	----------------	-------------------	----	--

Note1: Pull-Up resistor (4.7KOhm to 10 KOhm) is located within the CFP module Note2: PuH-Down resistor (4.7KOhm to 10 kOhm) is located within the CFP module

Management Interface Pins(MDIO)

The CFP Module supports alarm, control and monitor functions via an MDIO bus. The CFP MDIO pins are listed in the following table: Management Interface Pins

Pin#	Symbol	Description	I/O	Logic	H	L	Pull-up/down
41	GLB_ALRMn	Global Alarm	I	3.3V LVCMOS	Ok	Alarm	
47	MDIO	Management Data Input Output Bi-Directional Data	I/O	1.2V LVCMOS			
48	MDC	MDIO Clock	I	1.2V LVCMOS			
46	PRTADR0	MDIO Physical Port address bit0	I	1.2V LVCMOS	per MDIO document[5]		
45	PRTADR1	MDIO Physical Port address bit1	I	1.2V LVCMOS			
44	PRTADR2	MDIO Physical Port address bit2	I	1.2V LVCMOS			
43	PRTADR3	MDIO Physical Port address bit3	I	1.2V LVCMOS			
42	PRTADR4	MDIO Physical Port address bit4	I	1.2V LVCMOS			

Hardware Signaling Pin Timing Requirements

Parameter	Symbol	Min	Max	Unit	Notes&Conditions
Hardware MOD_LOPWR assert	t_MOD_LOPWR_a ssert		1	ms	Application Specific May depend on current state Condition when signal is applied .See
TX Disable Assert Time	T_off		100	us	

Timing Parameters for CFP hardware Signal Pins are listed in the following table.

high Speed Electrical Characteristics

Reference Clock Characteristics

		Min	Typ	Max	Unit	Notes
Impedance	Zd	80	100	120	Q	
Frequency			161.1328125/644.53125		MHz	1/64 or 1/16 of electrical lane rate
Frequency Stability	Δf	-100		100	ppm	For Ethernet applications
		-20		20		For Telecom applications
Output Differential Voltage	VDIFF	400		1200	mV	Peak to Peak Differential
RMS jitter1-2	0			10	ps	Random Jitter Over frequency band of 10KHz<f<10MHz
Clock Duty Cycle		40		60	%	
Clock Rise/Fall Time 10%/90%	tr/f	200		1250	ps	1/64 of electrical lane rate
		50		315		1/16 of electrical lane rate

Note1: The term "40GBASE_FR" is the 40GbE serial optical interface in the task force phase at IEEE-SA at the time of this publication. Also, 1/16 of optical lane clock is recommended for TX_MCLK and RX_MCLK

Note2: Multi-protocol modules are recommended to adopt the clock rate rate used in Telecom applications

Optional Transmitter and Receiver Monitor Clock Characteristics

		Min	Typ	Max	Unit	Notes
Impedance	Zd	80	100	120	Q	
Frequency					MHz	1/8 of Network lane rate
Output Differential Voltage	VDIFF	400		1200	mV	Peak to Peak Differential
Clock Duty Cycle		40		60	%	

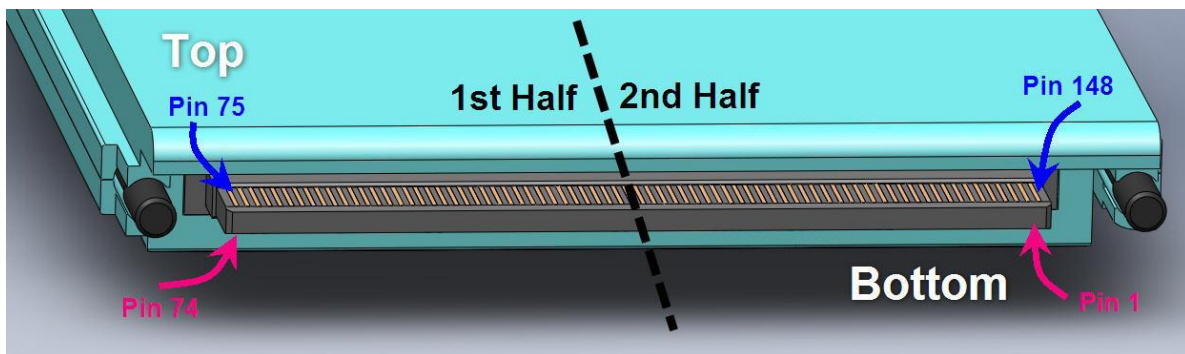

Pad Layout of the CFP module

CFP Optical Interface lanes and Assignment

shows the orientation of the multimode fiber facets of the optical connector.

Mechanical Specifications

Ordering information

Part Number	Product Description
GCF-S101-LR4C	CFP, 100GE/OTU4, 10km, 100GBASE-LR4, Pout -4.3 ~ +4.5 PIN <-8.6dBm

1. 100G Ethernet
2. 100G OTU4

Standards

Compliant with IEEE 802.3ba
Compliant with CFP MSA hardware specification
Compliant with CFP MSA management specification
Compliant with ITU-T G.709/Y.1331 Compliant with RoHS&WEEE

Important Notice

Performance figures, data and any illustrative material provided in this data sheet are typical and must be specifically confirmed in writing by GIGALIGHT before they become applicable to any particular order or contract. In accordance with the GIGALIGHT policy of continuous improvement specifications may change without notice.

The publication of information in this data sheet does not imply freedom from patent or other protective rights of GIGALIGHT or others. Further details are available from any GIGALIGHT sales representative.

E-mail: sales@gigalight.com.cn

Web : <http://www.gigalight.com>