

100GBASE-SR4 CFP4 Optical Transceiver

GF4-M101-SR4C

Features

- Hot pluggable CFP4 MSA form factor
- Supports 103.1Gb/s to 112.2Gb/s aggregate bit rates
- Compliant to IEEE 802.3bm 100GBASE-SR4
- Power class 2 (<2.5W max)
- Up to 70m on OM3 and 100m OM4 MMF transmission
- Up to 28Gb/s data rate per channel
- Operating case temperature: 0~70°C
- 4x28G Electrical Serial Interface (CEI-28G-VSR)
- MDIO management interface with digital diagnostic monitoring (Optional)
- Maximum power consumption <2.5W
- Utilizes a standard 12/8 lane optical fiber with MPO connector
- RoHS 6 compliant(lead free)
- 4×28Gb/s 850nm VCSEL-based transmitter



Applications

- 100GBASE-SR4 Ethernet
- OTN OTU4
- 128G Fiber Channel

Description

The Gigalight' s100Gb/s transceiver module for optical communication applications compliant to 100GBASE-SR4 of the IEEE P802.3bm standard. The module converts 4 input channels of 25Gb/s electrical data to 4 channels of VCSEL optical signals over 4 multimode fibers for 100Gb/s optical transmission. Reversely, on the receiver side, the module receives 4 channels of VCSEL optical signals over 4 multimode fibers and then converts them to 4 output channels of electrical data.

The high speed VCSEL transmitters and high sensitivity PIN receivers provide superior performance for 100Gigabit Ethernet applications up to 100m links over OM4 multimode fibers and compliant to optical interface with IEEE802.3bm Clause 95 100GBASE-SR4 requirements.

This product contains an MTP/MPO optical connector for the optical interface and a 56-pin connector for the electrical interface. Figure 1 shows the functional block diagram of this product.

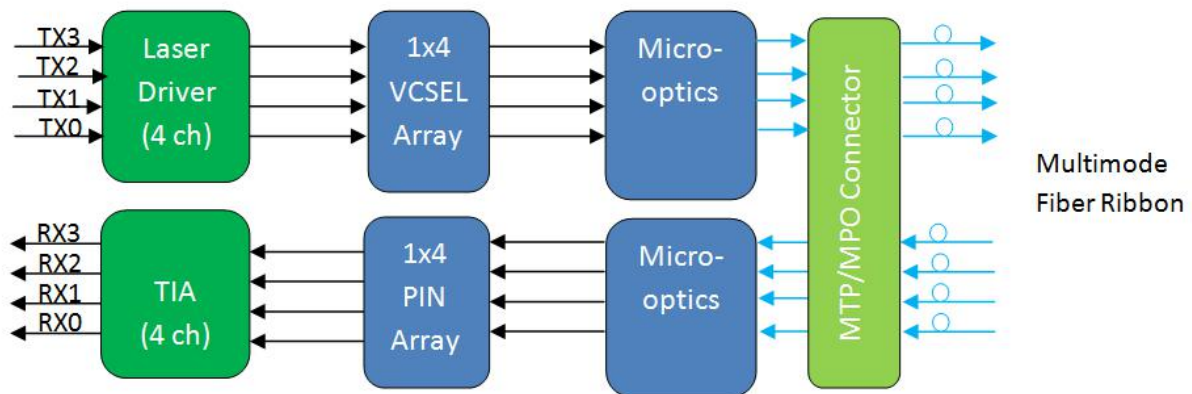

Figure 1. 100G CFP4 SR4 Transceiver Block Diagram

The CFP4 module supports the MDIO interface specified in IEEE802.3bm Clause 45. It supports alarm, control and monitor functions via hardware pins and via an MDIO bus. Upon module initialization, these functions are available. CFP4 MDIO electrical interface consists of 6 wires including 2 wires of MDC and MDIO, as well as 3 Port Address wires, and the Global Alarm wire. The CFP4 uses pins in the electrical connector to instantiate the MDIO interface as listed in Table 1. MDIO Interface Pins.

Table 1. MDIO Interface Pins

PIN	Symbol	Description	I/O	Logic	"H"	"L"
13	GLB_ALRMn	Global Alarm	O	3.3V LVCMOS	OK	Alarm
18	MDIO	Management Data Input Output Bi-Directional Data	I/O	1.2V LVCMOS		
17	MDC	MDIO Clock	I	1.2V LVCMOS		
19	PRTADR0	MDIO port address bit 0	I	1.2V LVCMOS	per MDIO document	
20	PRTADR1	MDIO port address bit 1	I	1.2V LVCMOS		
21	PRTADR2	MDIO port address bit 2	I	1.2V LVCMOS		

Pin Assignment and Description

The CFP4 electrical connector has 56 pins, which are arranged in top and bottom rows. The pin orientation is shown in Figure 2 and the pin map is shown in Table 2. The detailed description of the bottom side pins from pin 1 through pin 28 is shown in Table 3 while the description of the top side pins is shown in Table 4.

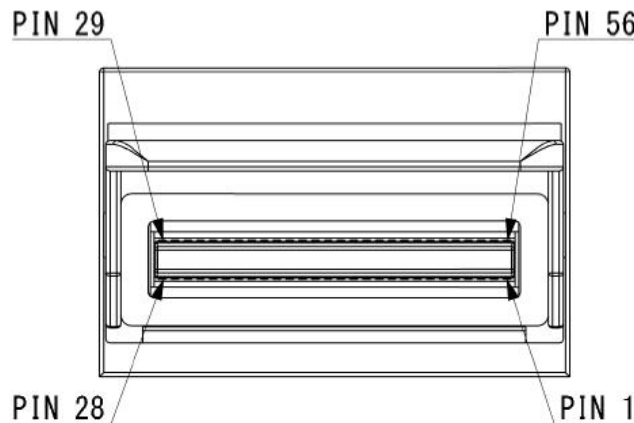

Figure 2. CFP4 Connector Pin Map Orientation

Table 2. Pin Map

CFP4 Bottom		CFP4 Top		CFP4 Top ALT1	
1	3.3V_GND	56	GND		GND
2	3.3V_GND	55	TX3n		TX0n
3	3.3V	54	TX3p		TX0p
4	3.3V	53	GND		GND
5	3.3V	52	TX2n		TX1n
6	3.3V	51	TX2p		TX1p
7	3.3V_GND	50	GND		GND
8	3.3V_GND	49	TX1n		TX2n
9	VND_IO_A	48	TX1p		TX2p
10	VND_IO_B	47	GND		GND
11	TX_DIS (PRG_CNTL1)	46	TX0n		TX3n
12	RX_LOS (PRG_ALRM1)	45	TX0p		TX3p
13	GLB_ALRMn	44	GND		GND
14	MOD_LOPWR	43	(REFCLKn)		(REFCLKn)
15	MOD_ABS	42	(REFCLKp)		(REFCLKp)
16	MOD_RSTn	41	GND		GND
17	MDC	40	RX3n		RX3p
18	MDIO	39	RX3p		RX3n
19	PRTADR0	38	GND		GND
20	PRTADR1	37	RX2n		RX2p
21	PRTADR2	36	RX2p		RX2n
22	VND_IO_C	35	GND		GND
23	VND_IO_D	34	RX1n		RX1p
24	VND_IO_E	33	RX1p		RX1n
25	GND	32	GND		GND
26	(MCLKn)	31	RX0n		RX0p
27	(MCLKp)	30	RX0p		RX0n
28	GND	29	GND		GND

REFCLK
(Optional)

MCLK = TX_MCLK +
RX_MCLK
(Optional)

Table 3. Definition of the Bottom Side Pins from Pin 1 through Pin 28

PIN	Name	I/O	Logic	Description
1	3.3V_GND			3.3V Module Supply Voltage Return Ground, can be separated or tied together with Signal Ground
2	3.3V_GND			GND
3	3.3V			3.3V Module Supply Voltage
4	3.3V			3.3V Module Supply Voltage
5	3.3V			3.3V Module Supply Voltage
6	3.3V			3.3V Module Supply Voltage
7	3.3V_GND			GND
8	3.3V_GND			GND
9	VIND_IO_A	I/O		Module Vendor I/O A. Do Not Connect
10	VIND_IO_B	I/O		Module Vendor I/O B. Do Not Connect

11	TX_DIS (PRG_CNT L1)	I	LVC MOS w/PUR	Transmitter Disable for all lanes. "1" or NC: Transmitter disabled; "0": transmitter enabled.(Optionally configurable as Programmable Control1 after Reset)
12	RX_LOS (PRG_ALR M1)	O	LVC MOS w/PUR	Receiver Loss of Optical Signal. "1": low optical signal; "0":normal condition (Optionally configurable as Programmable Alarm1 after Reset)
13	GLB_ALRM n	O	LVC MOS	Global Alarm. "0":alarm condition in any MDIO Alarm register; "1": no alarm condition, Open Drain, Pull up Resistor on Host
14	MOD_LOP WR	I	LVC MOS w/PUR	Module Low Power Mode. "1" or NC: module in low power (safe) mode; "0":power-on enabled
15	MOD_ABS	O	GND	Module Absent. "1" or NC: module absent; "0": module present, Pull up resistor on Host
16	MOD_RST n	I	LVC MOS w/PDR	Module Reset. "0": resets the module; "1" or NC: module enabled, Pull down Resistor in Module
17	MDC	I	1.2V CMOS	Management Data Clock (electrical specs as per IEEE Std 802.3-2012)
18	MDIO	I/O	1.2V CMOS	Management Data I/O bi-directional data(electrical specs as per IEEE Std 802.3ae-2008 and ba-2010)
19	PRTADR0	I	1.2V CMOS	MDIO Physical Port address bit 0
20	PRTADR1	I	1.2V CMOS	MDIO Physical Port address bit 1
21	PRTADR2	I	1.2V CMOS	MDIO Physical Port address bit 2
22	VND_IO_C	I/O		Module Vendor I/O C. Do Not Connect
23	VND_IO_D	I/O		Module Vendor I/O D. Do Not Connect
24	VND_IO_E	I/O		Module Vendor I/O E. Do Not Connect
25	GND			GND
26	(MCLKn)	O	CML	For optical waveform testing. Not for normal use
27	(MCLKp)	O	CML	For optical waveform testing. Not for normal use
28	GND			GND

Table 4. Definition of Top Side Pins

PIN	Name	PIN	Name
29	GND	43	(REFCLKp)
30	RX0p	44	GND
31	RX0n	45	TX0p
32	GND	46	TX0n
33	RX1p	47	GND
34	RX1n	48	TX1p
35	GND	49	TX1n
36	RX2p	50	GND
37	RX2n	51	TX2p
38	GND	52	TX2n
39	RX3p	53	GND
40	RX3n	54	TX3p
41	GND	55	TX3n
42	(REFCLKn)	56	GND

Optical Interface Lanes and Assignment

Figure 3 shows the orientation of the multi-mode fiber facets of the optical connector. Table 5 provides the lane assignment.

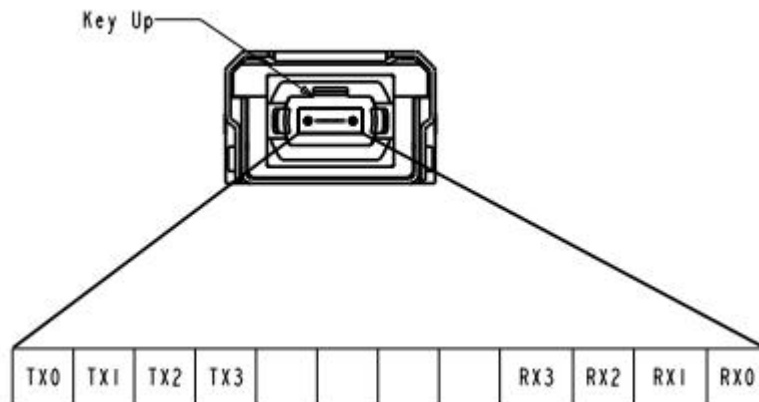

Figure 3. Outside View of the CFP4 Module MPO Receptacle

Table5: Lane Assignment

Fiber #	Lane Assignment
1	RX0
2	RX1
3	RX2
4	RX3
5,6,7,8	Not used
9	TX3
10	TX2
11	TX1
12	TX0

Absolute Maximum Ratings

Parameter	Symbol	Min	Max	Unit	Notes
Storage Temperature	T _s	-40	85	degC	
Relative Humidity (non-condensation)	RH		85	%	
Operating Case Temperature	T _{OP}	0	70	degC	
Supply Voltage	V _{cc}	-0.5	3.6	V	
Voltage on LVTTTL Input	V _{lvttl}	-0.5	V _{CC3} +0.3	V	
LVTTTL Output Current	I _{olvttl}		15	mA	
Voltage on Open Collector Output	V _{oco}	0	6	V	
Damage Threshold, each Lane	TH _d	3.4		dBm	1

Notes:

1. PIN receiver.

Recommended Operating Conditions and Supply Requirements

Parameter	Symbol	Min	Typical	Max	Unit	Notes
Operating Case Temperature	T _{OP}	0		70	degC	

Power Supply Voltage	V _{CC}	3.135	3.3	3.465	V	
Data Rate, each Lane			25.78125		Gbps	1
Data Rate, each Lane			27.9525		Gbps	2
Control Input Voltage High		2		V _{CC}	V	
Control Input Voltage Low		0		0.8	V	
Power Supply Noise	V _{rip}			2	%	DC-1MHz
				3	%	1-10MHz
Link Distance (OM3 MMF)	D1			70	m	
Link Distance (OM4 MMF)	D2			100	m	

Notes:

1. 100GBASE-SR4.
2. OUT4 with FEC.

Electrical Characteristics

Parameter	Symbol	Min	Typical	Max	Unit	Notes
Power Consumption				2.5	W	
Supply Current	I _{cc}			800	mA	
Low Power Mode Power Dissipation				1	W	
Transmitter (each Lane)						
Single-ended Input Voltage Tolerance (Note 1)		-0.3		4.0	V	Referred to TP1 signal common
AC Common Mode Input Voltage Tolerance		15			mV	RMS
Differential Input Voltage Swing Threshold		50			mV _p	LOSA Threshold
Differential Input Voltage Swing	V _{in,pp}	190		700	mV _p	
Differential Input Impedance	Z _{in}	90	100	110	Ohm	
Receiver (each Lane)						
Single-ended Output Voltage		-0.3		4.0	V	Referred to signal common
AC Common Mode Output Voltage				7.5	mV	RMS
Differential Output Voltage Swing	V _{out,pp}	300		850	mV _p	
Differential Output Impedance	Z _{out}	90	100	110	Ohm	
Termination Mismatch at 1MHz				5	%	

Notes:

1. The single ended input voltage tolerance is the allowable range of the instantaneous input signals.

Optical Characteristics

Parameter	Symbol	Min	Typical	Max	Units	Notes
Transmitter						
Center Wavelength	λ_c	840	850	860	nm	
RMS Spectral Width	$\Delta\lambda_{rms}$			0.6	nm	
Average Launch Power, each Lane	P_{AVG}	-8.4		2.4	dBm	
Optical Modulation Amplitude (OMA), each Lane	P_{OMA}	-6.4		3.0	dBm	1
Difference in Launch Power between any Two Lanes (OMA)	$P_{tx,diff}$			4.0	dB	
Launch Power in OMA minus TDEC, each Lane		-7.3			dBm	
Transmitter and Dispersion Eye Closure (TDEC), each Lane				4.3	dB	
Extinction Ratio	ER	2.0			dB	
Optical Return Loss Tolerance	TOL			12	dB	
Encircled Flux		$\geq 86\%$ at 19 μ m $\leq 30\%$ at 4.5 μ m				
Transmitter Eye Mask Definition {X1, X2, X3, Y1, Y2, Y3}, 5×10^{-5} hits/sample		{0.3,0.38,0.45,0.35,0.41,0.5}				2
Average Launch Power OFF Transmitter, each Lane	P_{off}			-30	dBm	
Receiver						
Center Wavelength	λ_c	840	850	860	nm	
Damage Threshold, each Lane	TH_d	3.4			dBm	3
Average Receive Power, each Lane		-10.3		2.4	dBm	
Receiver Reflectance	R_R			-12	dB	

Receive Power (OMA), each Lane				3.0	dBm	
Stressed Receiver Sensitivity (OMA), each Lane				-5.2	dBm	4
LOS Assert	LOSA	-30			dBm	
LOS Deassert	LOSD			-12	dBm	
LOS Hysteresis	LOSH	0.5	2		dB	
Conditions of Stress Receiver Sensitivity Test (Note 5):						
Stressed Eye Closure (SEC), Lane under Test			4.3		dB	
Stressed Eye J2 Jitter, Lane under Test			0.39		UI	
Stressed Eye J4 Jitter, Lane under Test				0.53	UI	
OMA of each Aggressor Lane			3		dBm	
Stressed receiver eye mask definition {X1, X2, X3, Y1, Y2, Y3}			{0.28,0.5,0.5,0.33,0.33,0.4}			

Notes:

1. Even if the TDP < 0.9 dB, the OMA min must exceed the minimum value specified here.
2. See Figure 5 below.
3. The receiver shall be able to tolerate, without damage, continuous exposure to a modulated optical input signal having this power level on one lane. The receiver does not have to operate correctly at this input power.
4. Measured with conformance test signal at receiver input for BER = 1×10^{-12} .
5. Stressed eye closure and stressed eye jitter are test conditions for measuring stressed receiver sensitivity. They are not characteristics of the receiver.

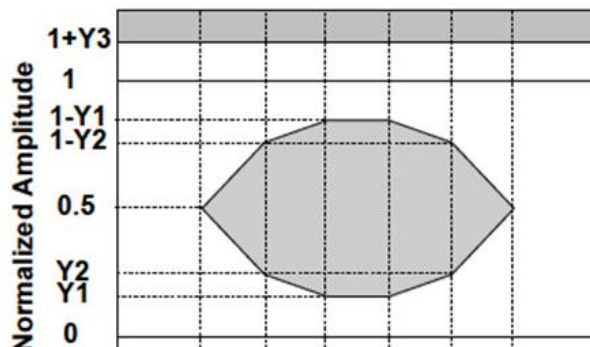

Digital Diagnostic Functions

The following digital diagnostic characteristics are defined over the Recommended Operating Environment unless otherwise specified. It is compliant to SFF-8436.

Parameter	Symbol	Min	Max	Units	Notes
Temperature monitor absolute error	DMI_Temp	-3	3	degC	Over operating temperature range
Supply voltage monitor absolute error	DMI_VCC	-0.15	0.15	V	Over full operating range
Channel RX power monitor absolute error	DMI_RX_Ch	-2	2	dB	1
Channel Bias current monitor	DMI_Ibias_Ch	-10%	10%	mA	Ch1~Ch4
Channel TX power monitor absolute error	DMI_TX_Ch	-2	2	dB	1

Notes:

1. Due to measurement accuracy of different single mode fibers, there could be an additional +/-1 dB fluctuation, or a +/- 3 dB total accuracy.

Mechanical Dimensions

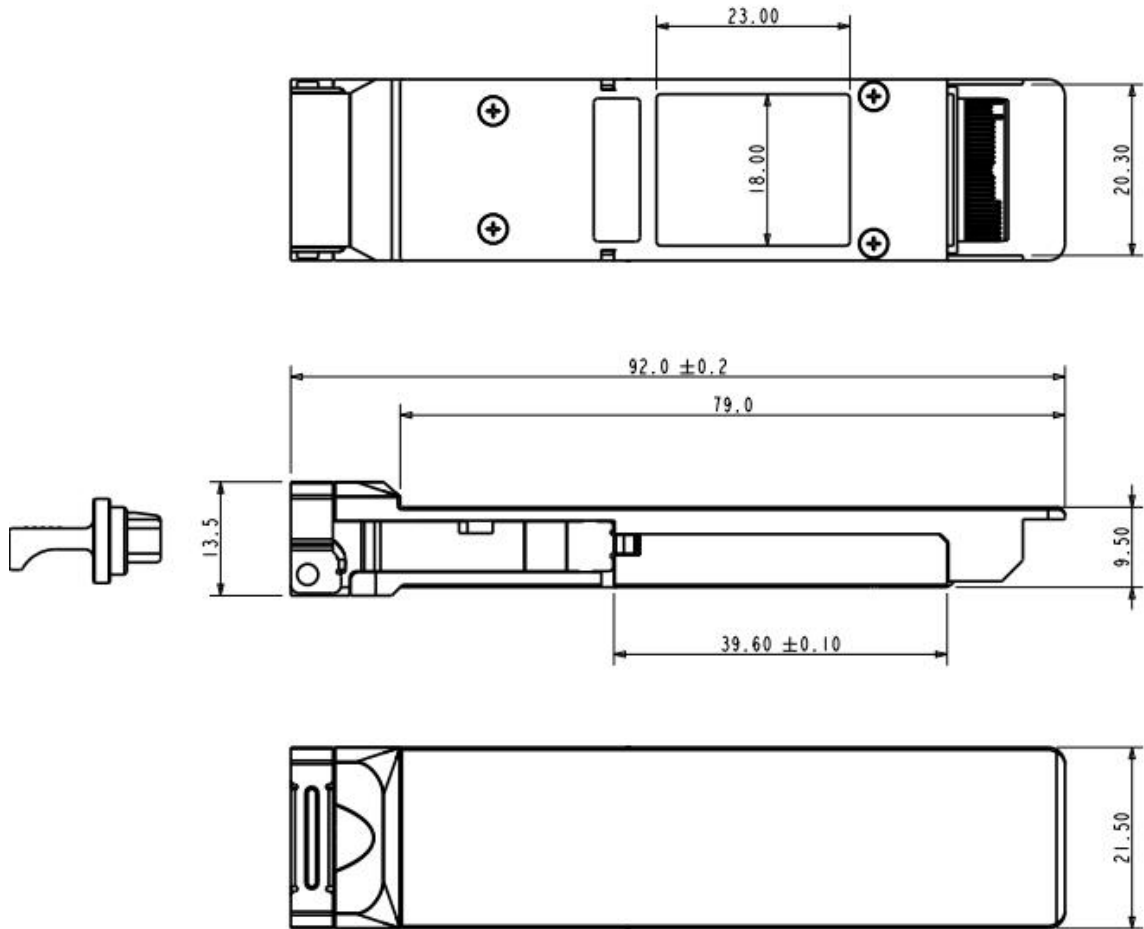

Figure 6.Mechanical Outline

ESD

This transceiver is specified as ESD threshold 2kV for all electrical input pins, tested per MIL-STD-883, Method 3015.4 /JESD22-A114-A (HBM). However, normal ESD precautions are still required during the handling of this module. This transceiver is shipped in ESD protective packaging. It should be removed from the packaging and handled only in an ESD protected environment.

Part Number Ordering Information

GF4-M101-SR4C	CFP4-SR4 100m optical transceiver with full real-time digital diagnostic monitoring and pull tab
---------------	--

Important Notice

Performance figures, data and any illustrative material provided in this data sheet are typical and must be specifically confirmed in writing by GIGALIGHT before they become applicable to any particular order or contract. In accordance with the GIGALIGHT policy of continuous improvement specifications may change without notice.

The publication of information in this data sheet does not imply freedom from patent or other protective rights of GIGALIGHT or others. Further details are available from any GIGALIGHT sales representative.

E-mail: sales@gigalight.com.cn

Web :<http://www.gigalight.com>