

100GE QSFP28 eSR4 850nm 300m Optical Transceiver Module

GQS-MPO101-eSR4C

Features

- ✓ Hot-pluggable QSFP28 form factor
- ✓ 4 channels full-duplex transceiver module
- ✓ Supports 4*25.78125Gb/s bit rate
- ✓ 4 channels 850nm VCSEL array
- ✓ 4 channels PIN photo-detector array
- ✓ Internal CDR circuits on both receiver and transmitter channels
- ✓ Supports CDR bypass
- ✓ 2W maximum power dissipation
- ✓ Maximum link length of 70m on OM3 MMF and 100m on OM4 MMF w/o FEC or 300m on OM4 MMF with FEC
- ✓ Single MTP/MPO receptacle
- ✓ Built-in digital diagnostic functions
- ✓ Operating case temperature range: 0°C to 70°C
- ✓ 3.3V power supply voltage
- ✓ RoHS 6 compliant (lead free)



Applications

- ✓ 100GBASE-SR4 100G Ethernet
- ✓ 40GBASE SR4 40G Ethernet

Description

The Gigalight Technologies GQS-MPO101-eSR4C is a Four-Channel, Pluggable, Parallel, Fiber-Optic QSFP28 SR4 for 100 or 40 Gigabit Ethernet and Infiniband FDR/EDR Applications. This transceiver is a high performance module for short-range multi-lane data communication and interconnect applications. Each lane can operate at 25.78125Gbps up to 70 m using OM3 fiber 100m using OM4 fiber w/o FEC or 300m OM4 MMF with KR-FEC. These modules are designed to operate over multimode fiber systems using a nominal wavelength of 850nm. The electrical interface uses a 38 contact edge type connector. The optical interface uses an 12 fiber MTP (MPO) connector. This module incorporates Gigalight Technologies proven circuit and VCSEL technology to provide reliable long life, high performance, and consistent service.

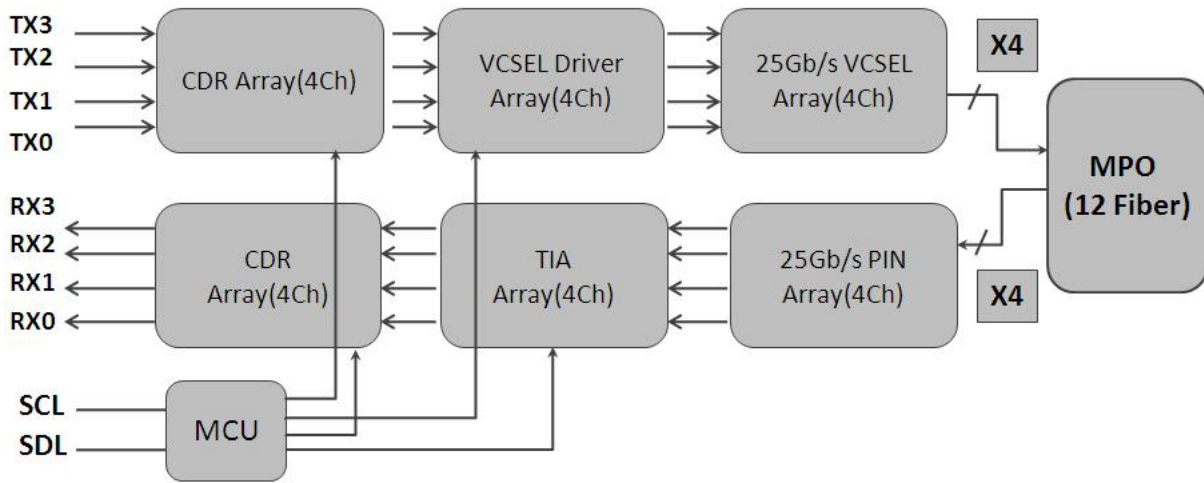

Figure 1. Module Block Diagram

The 100GBASE-SR4 multirate QSFP28 is a parallel transceiver with the key technique of VCSEL and PIN array package, and can be contacted through I2C system.

Absolute Maximum Ratings

Parameter	Symbol	Min	Max	Unit
Supply Voltage	V_{cc}	-0.3	3.6	V
Input Voltage	V_{in}	-0.3	$V_{cc}+0.3$	V
Storage Temperature	T_s	-20	85	°C
Case Operating Temperature	T_c	0	70	°C
Humidity (non-condensing)	Rh	5	95	%

Recommended Operating Conditions

Parameter	Symbol	Min	Typical	Max	Unit
Supply Voltage	V_{cc}	3.13	3.3	3.47	V
Operating Case Temperature	T_c	0		70	°C
Data Rate Per Lane	fd		25.78125		Gb/s
Humidity	Rh	5		85	%
Power Dissipation	P_m			2	W
Fiber Bend Radius	R_b	3			cm

Electrical Specifications

Parameter	Symbol	Min	Typical	Max	Unit
Differential Input Impedance	Z_{in}	90	100	110	ohm
Differential Output Impedance	Z_{out}	90	100	110	ohm
Differential Input Voltage Amplitude ¹	ΔV_{in}	300		1100	mVp-p
Differential Output Voltage Amplitude ²	ΔV_{out}	500		800	mVp-p
Skew	Sw			300	ps
Bit Error Rate	BER	5e-5	1e-12		
Input Logic Level High	V_{IH}	2.0		V_{cc}	V
Input Logic Level Low	V_{IL}	0		0.8	V
Output Logic Level High	V_{OH}	$V_{cc}-0.5$		V_{cc}	V
Output Logic Level Low	V_{OL}	0		0.4	V

Note:

1. Differential input voltage amplitude is measured between TxnP and TxnN.
2. Differential output voltage amplitude is measured between RxnP and RxnN.

Optical Characteristics

Parameter	Symbol	Min	Typical	Max	Unit
Transmitter					
Center Wavelength	λ_c	840	850	860	nm
RMS Spectral Width	$\Delta\lambda$			0.6	nm
Average Launch Power (each lane)	P_{out}	-8.4		2.4	dBm
Optical Modulation Amplitude (each lane)	OMA	-6.4		3	dBm
Transmitter and Dispersion Eye Closure (each)	TDEC			4.3	dB
Extinction Ratio	ER	3			dB
Average Launch Power of OFF Transmitter (each)	P_{off}			-30	dB
Eye Mask Coordinates ¹ : X1, X2, X3, Y1, Y2, Y3		{0.3, 0.38, 0.45, 0.35, 0.41, 0.5}			
Receiver					
Center Wavelength	λ_c	840	850	860	nm
Stressed Receiver Sensitivity in OMA ²				-5.2	dBm
Average Power at Receiver		-10.3		2.4	dBm
Receiver Reflectance	R_R			-12	dB
LOS Assert	LOS_A	-30			dBm
LOS De-Assert – OMA	LOS_D			-7.5	dBm
LOS Hysteresis	LOS_H	0.5			dB

Note:

1. Hit Ratio = 5×10^{-5}
2. Measured with conformance test signal at TP3 for BER=1E-12

Pin Description

Pin	Logic	Symbol	Name/Description
1		GND	Module Ground ¹
2	CML-I	Tx2-	Transmitter inverted data input
3	CML-I	Tx2+	Transmitter non-inverted data input
4		GND	Module Ground ¹
5	CML-I	Tx4-	Transmitter inverted data input
6	CML-I	Tx4+	Transmitter non-inverted data input
7		GND	Module Ground ¹
8	LVTTL-I	MODSEIL	Module Select ²
9	LVTTL-I	ResetL	Module Reset ²
10		VCCRx	+3.3V Receiver Power Supply
11	LVC MOS-I	SCL	2-wire Serial interface clock ²
12	LVC MOS-I/O	SDA	2-wire Serial interface data ²
13		GND	Module Ground ¹
14	CML-O	RX3+	Receiver non-inverted data output
15	CML-O	RX3-	Receiver inverted data output
16		GND	Module Ground ¹
17	CML-O	RX1+	Receiver non-inverted data output
18	CML-O	RX1-	Receiver inverted data output
19		GND	Module Ground ¹
20		GND	Module Ground ¹
21	CML-O	RX2-	Receiver inverted data output
22	CML-O	RX2+	Receiver non-inverted data output
23		GND	Module Ground ¹
24	CML-O	RX4-	Receiver inverted data output
25	CML-O	RX4+	Receiver non-inverted data output
26		GND	Module Ground ¹
27	LVTTL-O	ModPrsL	Module Present, internal pulled down to GND
28	LVTTL-O	IntL	Interrupt output, should be pulled up on host board ²
29		VCCTx	+3.3V Transmitter Power Supply
30		VCC1	+3.3V Power Supply
31	LVTTL-I	LPMODE	Low Power Mode ²
32		GND	Module Ground ¹
33	CML-I	Tx3+	Transmitter non-inverted data input
34	CML-I	Tx3-	Transmitter inverted data input
35		GND	Module Ground ¹
36	CML-I	Tx1+	Transmitter non-inverted data input
37	CML-I	Tx1-	Transmitter inverted data input
38		GND	Module Ground ¹

Note:

1. Module circuit ground is isolated from module chassis ground within the module.
2. Open collector should be pulled up with 4.7K to 10K ohms on host board to a voltage between 3.15V and 3.6V.

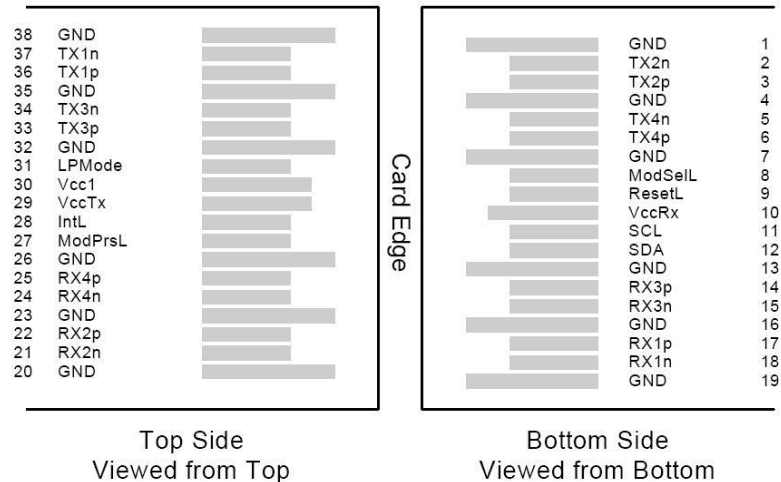

Figure 2. Electrical Pin-out Details

ModSelL Pin

The ModSelL is an input pin. When held low by the host, the module responds to 2-wire serial communication commands. The ModSelL allows the use of multiple QSFP modules on a single 2-wire interface bus. When the ModSelL is "High", the module will not respond to any 2-wire interface communication from the host. ModSelL has an internal pull-up in the module.

ResetL Pin

Reset. LPMODE_Reset has an internal pull-up in the module. A low level on the ResetL pin for longer than the minimum pulse length (t_{Reset_init}) initiates a complete module reset, returning all user module settings to their default state. Module Reset Assert Time (t_{init}) starts on the rising edge after the low level on the ResetL pin is released. During the execution of a reset (t_{init}) the host shall disregard all status bits until the module indicates a completion of the reset interrupt. The module indicates this by posting an IntL signal with the Data_Not_Ready bit negated. Note that on power up (including hot insertion) the module will post this completion of reset interrupt without requiring a reset.

LPMODE Pin

Gigalight QSFP28 modules operate in the low power mode (less than 1.5 W power consumption). This pin active high will decrease power consumption to less than 1W.

ModPrsL Pin

ModPrsL is pulled up to Vcc on the host board and grounded in the module. The ModPrsL is asserted "Low" when the module is inserted and deasserted "High" when the module is physically absent from the host connector.

IntL Pin

IntL is an output pin. When "Low", it indicates a possible module operational fault or a status critical to the host system. The host identifies the source of the interrupt by using the 2-wire serial interface. The IntL pin is an open collector output and must be pulled up to Vcc on the host board.

Power Supply Filtering

The host board should use the power supply filtering shown in Figure 3.

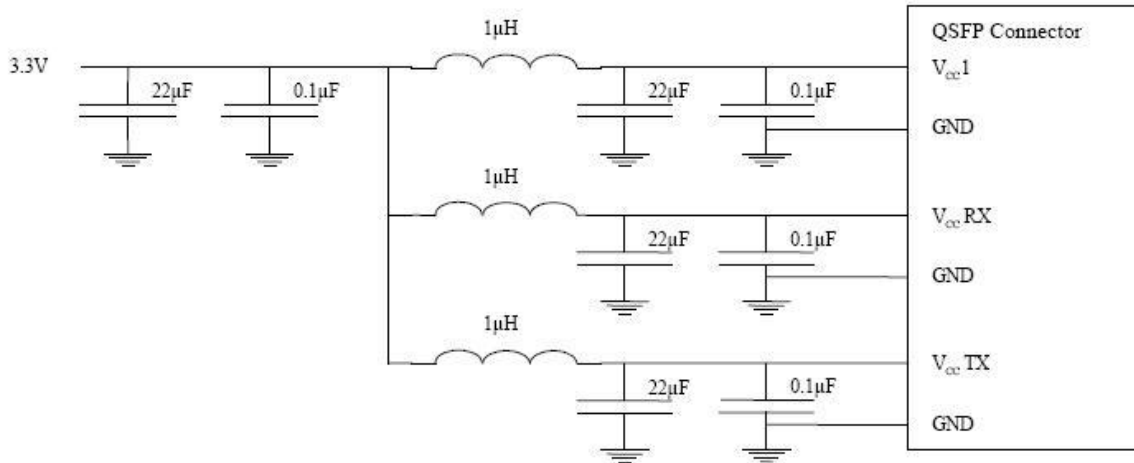
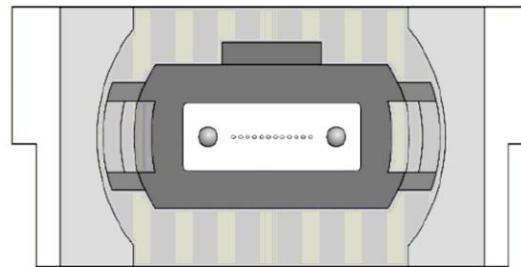

Figure 3. Host Board Power Supply Filtering

Optical Interface Lanes and Assignment

The optical interface port is a male MPO connector. The four fiber positions on the left as shown in Figure 4, with the key up, are used for the optical transmit signals (Channel 1 through 4). The fiber positions on the right are used for the optical receive signals (Channel 4 through 1). The central four fibers are physically present.



Transmit Channels: 1 2 3 4
 Unused positions: x x x x
 Receive Channels: 4 3 2 1

Figure 4. Optical Receptacle and Channel Orientation

DIAGNOSTIC MONITORING INTERFACE

Digital diagnostics monitoring function is available on all Gigalight QSFP28 transceivers. A 2-wire serial interface provides user to contact with module.

The structure of the memory is shown in Figure 5. The memory space is arranged into a lower, single page, address space of 128 bytes and multiple upper address space pages. This structure permits timely access to addresses in the lower page, such as Interrupt Flags and Monitors. Less time critical time entries, such as serial ID information and threshold settings, are available with the Page Select function.

The interface address used is A0xh and is mainly used for time critical data like interrupt handling in order to enable a one-time-read for all data related to an interrupt situation. After an interrupt, IntL, has been asserted, the host can read out the flag field to determine the affected channel and type of flag.

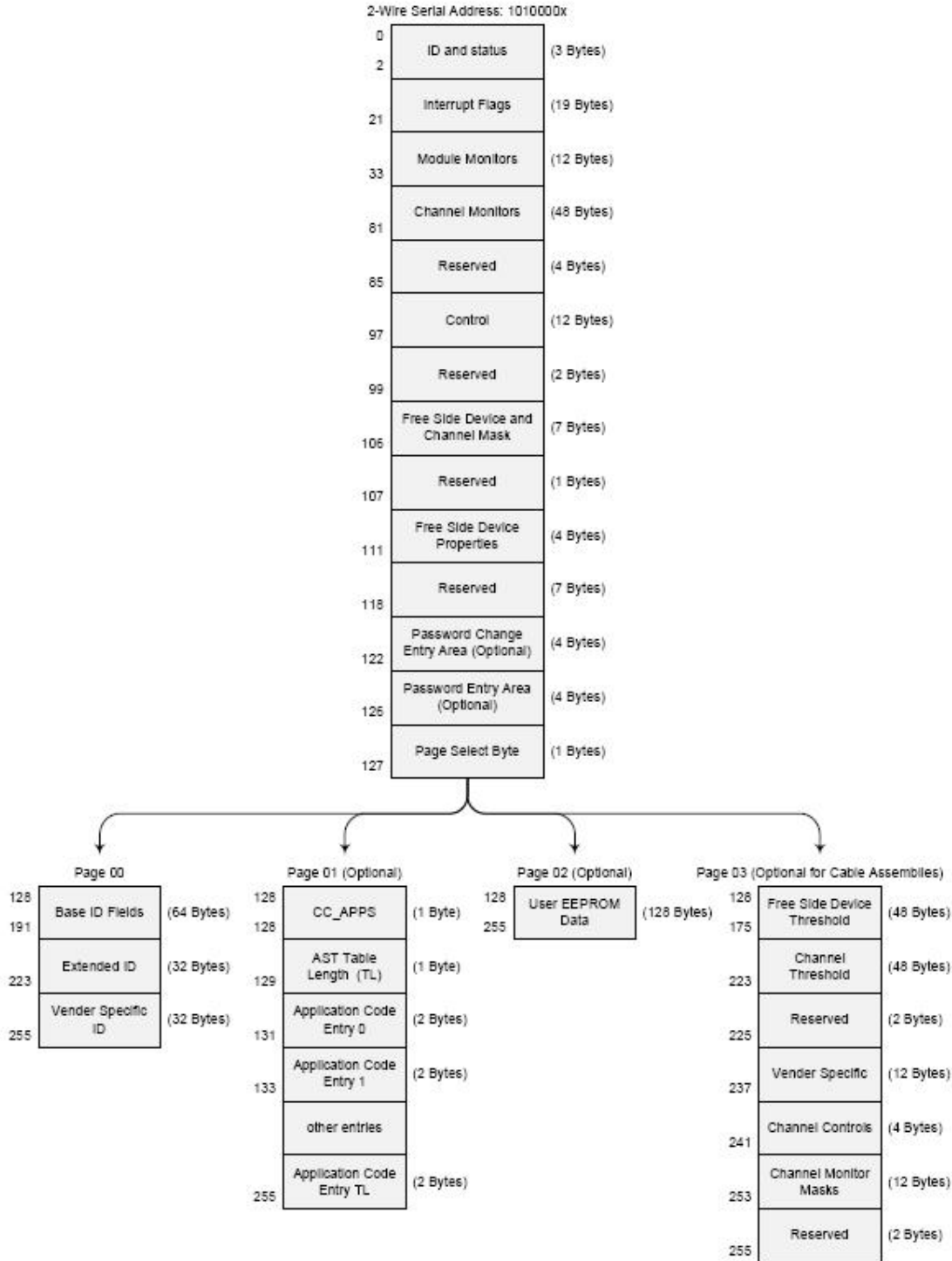

Figure 5. QSFP28 Memory Map

Byte Address	Description	Type
0	Identifier (1 Byte)	Read Only
1-2	Status (2 Bytes)	Read Only
3-21	Interrupt Flags (31 Bytes)	Read Only
22-33	Module Monitors (12 Bytes)	Read Only
34-81	Channel Monitors (48 Bytes)	Read Only
82-85	Reserved (4 Bytes)	Read Only
86-97	Control (12 Bytes)	Read/Write
98-99	Reserved (2 Bytes)	Read/Write
100-106	Module and Channel Masks (7 Bytes)	Read/Write
107-118	Reserved (12 Bytes)	Read/Write
119-122	Reserved (4 Bytes)	Read/Write
123-126	Reserved (4 Bytes)	Read/Write
127	Page Select Byte	Read/Write

Figure 6. Low Memory Map

Byte Address	Description	Type
128-175	Module Thresholds (48 Bytes)	Read Only
176-223	Reserved (48 Bytes)	Read Only
224-225	Reserved (2 Bytes)	Read Only
226-239	Reserved (14 Bytes)	Read/Write
240-241	Channel Controls (2 Bytes)	Read/Write
242-253	Reserved (12 Bytes)	Read/Write
254-255	Reserved (2 Bytes)	Read/Write

Figure 7. Page 03 Memory Map

Address	Name	Description
128	Identifier (1 Byte)	Identifier Type of serial transceiver
129	Ext. Identifier (1 Byte)	Extended identifier of serial transceiver
130	Connector (1 Byte)	Code for connector type
131-138	Transceiver (8 Bytes)	Code for electronic compatibility or optical compatibility
139	Encoding (1 Byte)	Code for serial encoding algorithm
140	BR, nominal (1 Byte)	Nominal bit rate, units of 100 Mbits/s
141	Extended RateSelect Compliance (1 Byte)	Tags for Extended RateSelect compliance
142	Length SMF (1 Byte)	Link length supported for SM fiber in km
143	Length E-50 μm (1 Byte)	Link length supported for EBW 50/125 μm fiber, units of 2 m
144	Length 50 μm (1 Byte)	Link length supported for 50/125 μm fiber, units of 1 m
145	Length 62.5 μm (1 Byte)	Link length supported for 62.5/125 μm fiber, units of 1 m
146	Length copper (1 Byte)	Link length supported for copper, units of 1 m
147	Device Tech (1 Byte)	Device technology
148-163	Vendor name (16 Bytes)	QSFP vendor name (ASCII)
164	Extended Transceiver (1 Byte)	Extended Transceiver Codes for InfiniBand [†]
165-167	Vendor OUI (3 Bytes)	QSFP vendor IEEE vendor company ID
168-183	Vendor PN (16 Bytes)	Part number provided by QSFP vendor (ASCII)
184-185	Vendor rev (2 Bytes)	Revision level for part number provided by vendor (ASCII)
186-187	Wavelength (2 Bytes)	Nominal laser wavelength (Wavelength = value / 20 in nm)
188-189	Wavelength Tolerance (2 Bytes)	Guaranteed range of laser wavelength (+/- value) from Nominal wavelength (Wavelength Tol. = value / 200 in nm)
190	Max Case Temp (1 Byte)	Maximum Case Temperature in Degrees C
191	CC_BASE (1 Byte)	Check code for Base ID fields (addresses 128-190)
192-195	Options (4 Bytes)	Rate Select, TX Disable, TX Fault, LOS
196-211	Vendor SN (16 Bytes)	Serial number provided by vendor (ASCII)
212-219	Date code (8 Bytes)	Vendor's manufacturing date code
220	Diagnostic Monitoring Type (1 Byte)	Indicates which type of diagnostic monitoring is implemented
221	Enhanced Options (1 Byte)	Indicates which optional enhanced features are implemented
222	Reserved (1 Byte)	Reserved
223	CC_EXT	Check code for the Extended ID Fields (addresses 192-222)
224-255	Vendor Specific (32 Bytes)	Vendor Specific EEPROM

Figure 8. Page 00 Memory Map

Page02 is User EEPROM and its format decided by user.

The detail description of low memory and Page 00. Page 03 upper memory please see SFF-8436 document.

Timing for Soft Control and Status Functions

Parameter	Symbol	Max	Unit	Conditions
Initialization Time	t_init	2000	ms	Time from power on ¹ , hot plug or rising edge of Reset until the module is fully functional ²
Reset Init Assert Time	t_reset_init	2	μs	A Reset is generated by a low level longer than the minimum reset pulse time present on the

Serial Bus Hardware Ready Time	t_serial	2000	ms	Time from power on ¹ until module responds to data transmission over the 2-wire serial bus
Monitor Data Ready Time	t_data	2000	ms	Time from power on ¹ to data not ready, bit 0 of Byte 2, deasserted and IntL asserted
Reset Assert Time	t_reset	2000	ms	Time from rising edge on the ResetL pin until the module is fully functional ²
LPMODE Assert Time	ton_LPMODE	100	μs	Time from assertion of LPMODE (V_{in} : LPMODE= V_{IH}) until module power consumption enters lower Power Level
IntL Assert Time	ton_IntL	200	ms	Time from occurrence of condition triggering IntL until V_{out} : IntL= V_{OL}
IntL Deassert Time	toff_IntL	500	μs	Time from clear on read ³ operation of associated flag until V_{out} : IntL= V_{OH} . This includes deassert times for Rx LOS, Tx Fault and other flag bits.
Rx LOS Assert Time	ton_los	100	ms	Time from Rx LOS state to Rx LOS bit set and IntL asserted
Tx Fault Assert Time	ton_Txfault	200	ms	Time from Tx Fault state to Tx Fault bit set and IntL asserted
Flag Assert Time	ton_flag	200	ms	Time from occurrence of condition triggering flag to associated flag bit set and IntL asserted
Mask Assert Time	ton_mask	100	ms	Time from mask bit set ⁴ until associated IntL assertion is inhibited
Mask Deassert Time	toff_mask	100	ms	Time from mask bit cleared ⁴ until associated IntL operation resumes
ModSelL Assert Time	ton_ModSelL	100	μs	Time from assertion of ModSelL until module responds to data transmission over the 2-wire
ModSelL Deassert Time	toff_ModSelL	100	μs	Time from deassertion of ModSelL until the module does not respond to data transmission over the 2-wire serial bus
Power_override or Power-set Assert Time	ton_Pdown	100	ms	Time from P_Down bit set ⁴ until module power consumption enters lower Power Level
Power_override or Power-set Deassert	toff_Pdown	300	ms	Time from P_Down bit cleared ⁴ until the module is fully functional ³

Note:

1. Power on is defined as the instant when supply voltages reach and remain at or above the minimum specified value.
2. Fully functional is defined as IntL asserted due to data not ready bit, bit 0 byte 2 deasserted.
3. Measured from falling clock edge after stop bit of read transaction.
4. Measured from falling clock edge after stop bit of write transaction.

Mechanical Dimensions

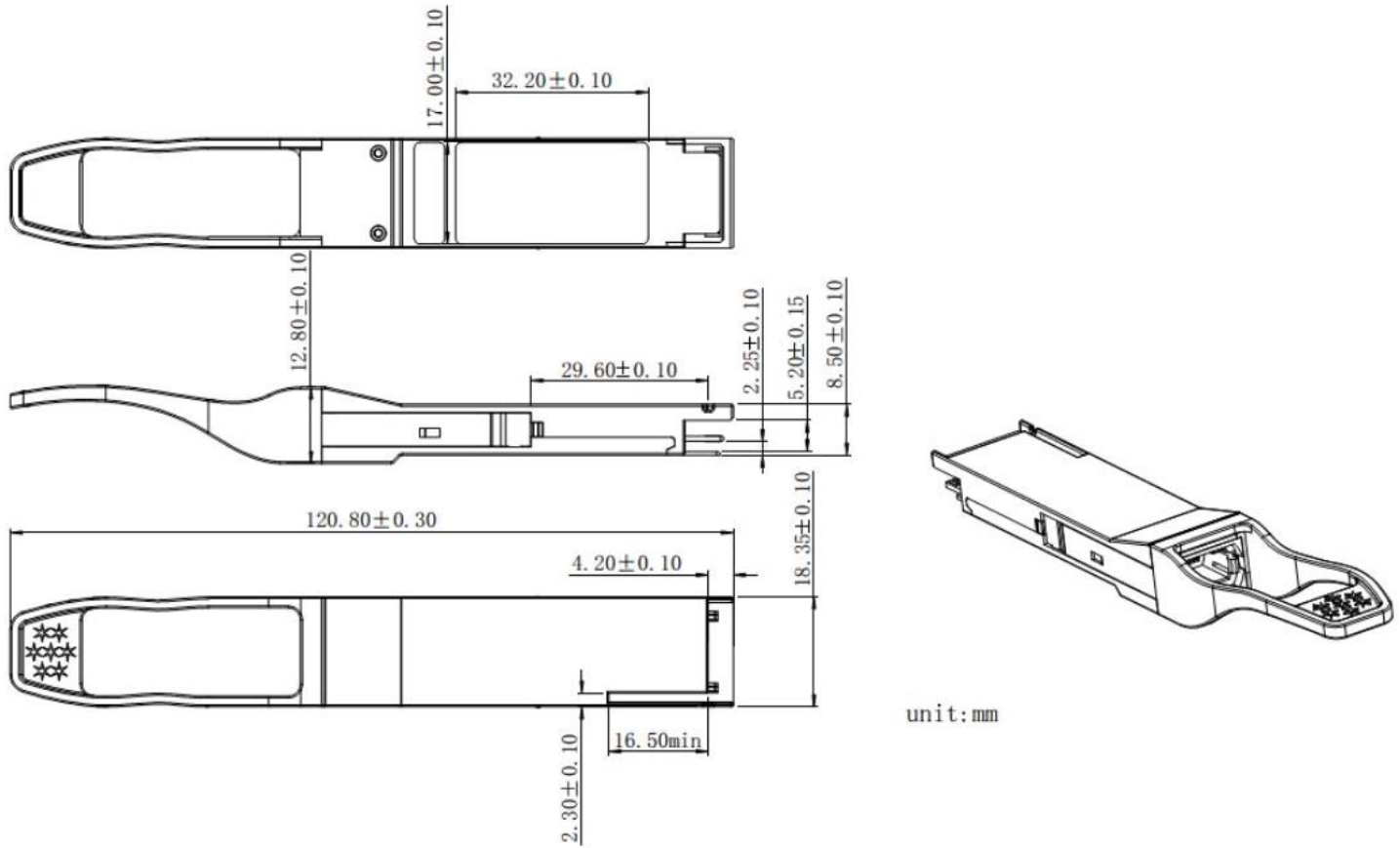

Figure 9. Mechanical Specifications

Regulatory Compliance

Gigalight GQS-MPO101-eSR4C QSFP28 transceivers are Class 1 Laser Products. They are certified per the following standards:

Feature	Agency	Standard
Laser Eye Safety	FDA/CDRH	CDRH 21 CFR 1040 and Laser Notice 50
EMC	FCC	47 CFR FCC Part 15 Subpart B
EMC	CE-EMC	EN 55032:2015 EN55035:2017

Complies with FDA performance standards for laser products except for deviations pursuant to Laser Notice No. 50, dated June 24, 2007.

References

1. QSFP28 MSA
2. Ethernet 100GBASE-SR4 IEEE802.3bm
3. 128GFC Specification, per ANSI T.11 FC-PI-6P.
4. IEEE 802.3bm, PMD Type 100GBASE-SR4 and CAUI-4.
5. Directive 2011/65/EU of the European Parliament and of the Council, "on the restriction of the use of certain hazardous substances in electrical and electronic equipment," July 1, 2011.

CAUTION:

Use of controls or adjustment or performance of procedures other than those specified herein may result in hazardous radiation exposure.

Ordering Information

Part Number	Product Description
GQS-MPO101-eSR4C	QSFP28 SR4, 4*25.78125Gb/s, 850nm, 100m OM4 MMF w/o FEC or 300m OM4 MMF with FEC , MTP/MPO

Important Notice

Performance figures, data and any illustrative material provided in this data sheet are typical and must be specifically confirmed in writing by Gigalight before they become applicable to any particular order or contract.

In accordance with the Gigalight policy of continuous improvement specifications may change without notice.

The publication of information in this data sheet does not imply freedom from patent or other protective rights of Gigalight or others. Further details are available from any Gigalight sales representative.

E-mail: sales@gigalight.com

Official Site: www.gigalight.com

Revision History

Revision	Date	Description
V0	March-27- 2020	Release.