

GIGALIGHT 80KM 50GHz DWDM SFP+ Optical Transceiver GDP-XXX192-08C

Features

- ◆ Compliant with SFF-8431, SFF-8432 and IEEE802.3ae
- ◆ 10GBASE-ZR, and 2G/4G/ 8G/10G Fiber Channel applications.
- ◆ Suitable for use in 100GHz/50GHz channel spacing DWDM systems
- ◆ Cooled EML transmitter and APD receiver
- ◆ link length up to 80km
- ◆ Low Power Dissipation 1.4W Typical (Maximum:2W)
- ◆ -5°C to 70°C Operating Case Temperature
- ◆ Single 3.3V power supply
- ◆ Diagnostic Performance Monitoring of module temperature, supply Voltages, laser bias current, transmit optical power, receive optical power
- ◆ RoHS6 compliant and lead free 



Applications

- ◆ 10G Ethernet (with/without FEC)
- ◆ 10G Fiber Channel

Description

Gigalight SFP+ZR DWDM Transceiver is a “Limiting module”, designed for 10G Ethernet, and 2G/4G/ 8G/10G Fiber- Channel applications.

The transceiver consists of two sections: The transmitter section incorporates a cooled EML laser. And the receiver section consists of a APD photodiode integrated with a TIA. All modules satisfy class I laser safety requirements. Digital diagnostics functions are available via a 2-wire serial interface, as specified in SFF-8472, which allows real-time access to device operating parameters such as transceiver temperature, laser bias current, transmitted optical power, received optical power and transceiver supply voltage.

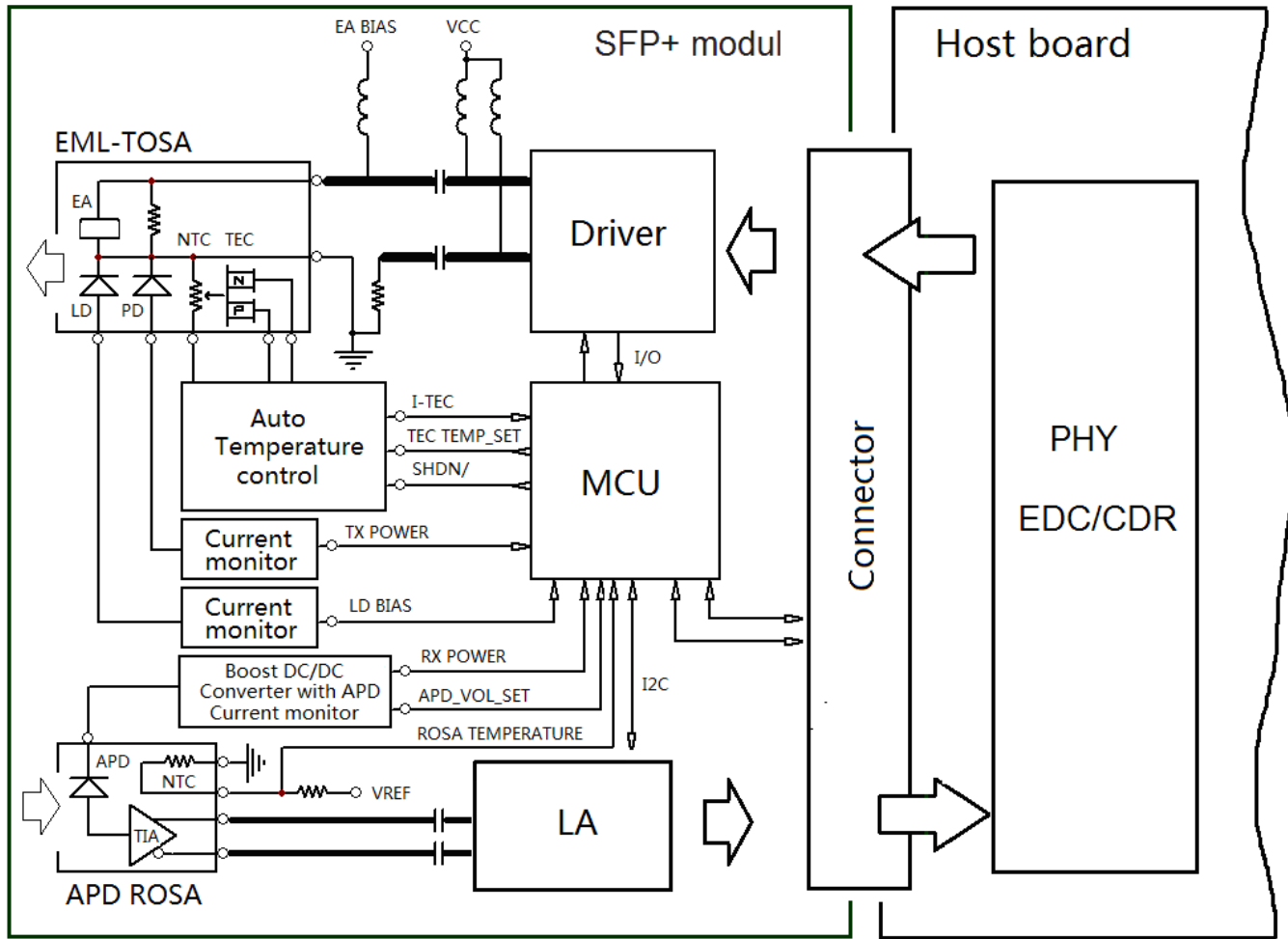

Gigalight 2011 --HHC

Figure1. Module Block Diagram

Absolute Maximum Ratings

Parameter	Symbol	Min	Max	Unit
Supply Voltage	Vcc	-0.5	3.8	V
Storage Temperature	Tst	-40	85	°C
Relative Humidity	Rh	0	85	%

Operating Conditions

Parameter	Symbol	Min	Typical	Max	Unit
Supply Voltage	Vcc	3.13	3.3	3.47	V
Supply current	Icc	-	420	610	mA
Operating Case temperature	Tca	-5	-	70	°C
Module Power Dissipation	Pm	-	1.4	2	W

Transmitter Specifications – Optical

Parameter	Symbol	Min	Typical	Max	Unit
Center Wavelength-Start of Life [1]	λ_c	$\lambda_c - 25$	λ_c	$\lambda_c + 25$	pm
Center Wavelength-End of life [1]	λ_c	$\lambda_c - 100$	λ_c	$\lambda_c + 100$	pm
Spectral Width (-20dB)	$\Delta\lambda_{20}$	-	-	0.3	nm
Average Optical Power [2]	Po	-1	-	+3	dBm
Side Mode Suppression Ratio	SMSR	30	-	-	dB
Optical Transmit Power (disabled)	PTX_DISABLE	-	-	-30	dBm
Extinction Ratio	ER	8.2	-	-	dB
Relative Intensity Noise	RIN	-	-	-128	dB/Hz
Optical Return Loss Tolerance	Orl	-	-	21	dB

Notes:

- Wavelength stability is achieved within 60 seconds (max) of power up. λ_c refer to wavelength selection, and corresponds to approximately 0.4 nm.
- Minimum OMA = -2.4 dBm.

Receiver Specifications – Optical

Parameter	Symbol	Min	Typical	Max	Unit		
Input Operating Wavelength	λ	1260	-	1620	nm		
Receiver Reflectance	Rrx			-27	dB		
Sensitivity (0Km)	Bit Rate(Gb/s)	BER					
	8.5,9.95~10.3Gb/s [1]	10^{-12}	Rsen1	-	-	-24	dBm
Sensitivity (80Km)	8.5,9.95~10.3Gb/s [1]	10^{-12}	Rsen2	-	-	-22	dBm
Maximum Input Power	RX-overload	-7	-		dBm		
Loss of Signal Asserted	Lsa	-34	-	-	dBm		
LOS De-Asserted	Lda	-	-	-24	dBm		
LOS Hysteresis	Lh	0.5	-	-	dB		

Notes:

[1] Measured with worst ER=9 dB; PRBS 231 – 1. For 10GEthernet application, -24dBm is equivalent to an OMA of -22.09dBm for an ER = 9 dB. The receiver sensitivity over fiber may vary depending on the host's clock and data recovery model.

Transmitter Specifications – Electrical

Parameter	Symbol	Min	Typical	Max	Unit
Data Rate	Mra	0.6	10.3	11.3	Gbps
Input differential impedance	Rim	-	100	-	Ω
Differential data Input	VtxDIFF	120	-	850	mV
Transmit Disable Voltage	VD	2.0	-	Vcc3+0.3	V
Transmit Enable Voltage	Ven	0	-	+0.8	V
Transmit Disable Assert Time	Vn	-	-	100	us

Receiver Specifications – Electrical

Parameter	Symbol	Min	Typical	Max	Unit
Data Rate	Mra	0.6	10.3	11.3	Gbps
Differential Output Swing	Vout P-P	350	-	850	mV
Rise/Fall Time	Tr / Tf	24	-	-	ps
Loss of Signal –Asserted	VOH	2	-	Vcc3+0.3-	V
Loss of Signal –Negated	VOL	0	-	+0.4	V

Digital Diagnostic Functions

Parameter	Symbol	Min.	Max	Unit	Notes
Accuracy					
Transceiver Temperature	DMI_Temp	-3	+3	degC	Over operating temp
TX Output optical power	DMI_TX	-3	+3	dB	
RX Input optical power	DMI_RX	-3	+3	dB	-3dBm to -12dBm range
Transceiver Supply voltage	DMI_VCC	-0.08	+0.08	V	Full operating range
Bias current monitor	DMI_Ibias	-10%	10%	mA	
Dynamic Range Accuracy					
Transceiver Temperature	DMI_Temp	-5	70	degC	
TX Output optical power	DMI_TX	-1	+2	dBm	
RX Input optical power	DMI_RX	-26	-7	dBm	

Transceiver Supply voltage	DMI_VCC	3.0	3.6	V	
Bias current monitor	DMI_Ibias	0	100	mA	

C-band λ c Wavelength Guide_50GHz

ITU Channel Product Code	Frequency(THz)	Wavelength	ITU Channel Product Code	Frequency(THz)	Wavelength
17	191.70	1563.86	40	194.00	1545.32
17.5	191.75	1563.45	40.5	194.05	1544.92
18	191.80	1563.05	41	194.10	1544.53
18.5	191.85	1562.64	41.5	194.15	1544.13
19	191.90	1562.23	42	194.20	1543.73
19.5	191.95	1561.83	42.5	194.25	1543.33
20	192.00	1561.42	43	194.30	1542.94
20.5	192.05	1561.01	43.5	194.35	1542.54
21	192.10	1560.61	44	194.40	1542.14
21.5	192.15	1560.20	44.5	194.45	1541.75
22	192.20	1559.79	45	194.50	1541.35
22.5	192.25	1559.39	45.5	194.55	1540.95
23	192.30	1558.98	46	194.60	1540.56
23.5	192.35	1558.58	46.5	194.65	1540.16
24	192.40	1558.17	47	194.70	1539.77
24.5	192.45	1557.77	47.5	194.75	1539.37
25	192.50	1557.36	48	194.80	1538.98
25.5	192.55	1556.96	48.5	194.85	1538.58
26	192.60	1556.55	49	194.90	1538.19
26.5	192.65	1556.15	49.5	194.95	1537.79
27	192.70	1555.75	50	195.00	1537.40
27.5	192.75	1555.34	50.5	195.05	1537.00
28	192.80	1554.94	51	195.10	1536.61
28.5	192.85	1554.54	51.5	195.15	1536.22
29	192.90	1554.13	52	195.20	1535.82
29.5	192.95	1553.73	52.5	195.25	1535.43

30	193.00	1553.33	53	195.30	1535.04
30.5	193.05	1552.93	53.5	195.35	1534.64
31	193.10	1552.52	54	195.40	1534.25
31.5	193.15	1552.12	54.5	195.45	1533.86
32	193.20	1551.72	55	195.50	1533.47
32.5	193.25	1551.32	55.5	195.55	1533.07
33	193.30	1550.92	56	195.60	1532.68
33.5	193.35	1550.52	56.5	195.65	1532.29
34	193.40	1550.12	57	195.70	1531.90
34.5	193.45	1549.72	57.5	195.75	1531.51
35	193.50	1549.32	58	195.80	1531.12
35.5	193.55	1548.91	58.5	195.85	1530.72
36	193.60	1548.51	59	195.90	1530.33
37.5	193.75	1547.32	59.5	195.95	1529.94
38	193.80	1546.92	60	196.00	1529.55
38.5	193.85	1546.52	60.5	196.05	1529.16
39	193.90	1546.12	61	196.10	1528.77
39.5	193.95	1545.72			

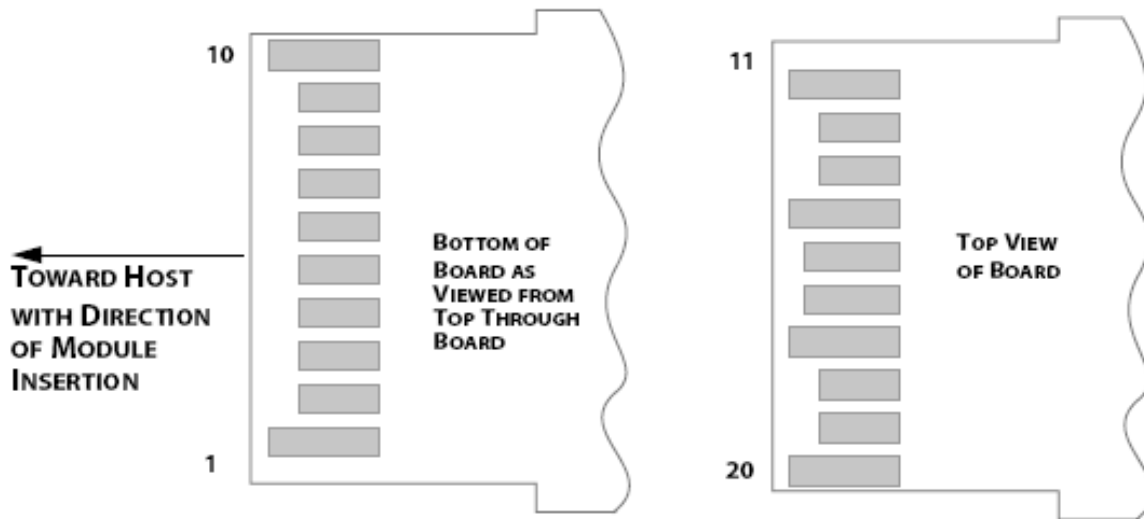
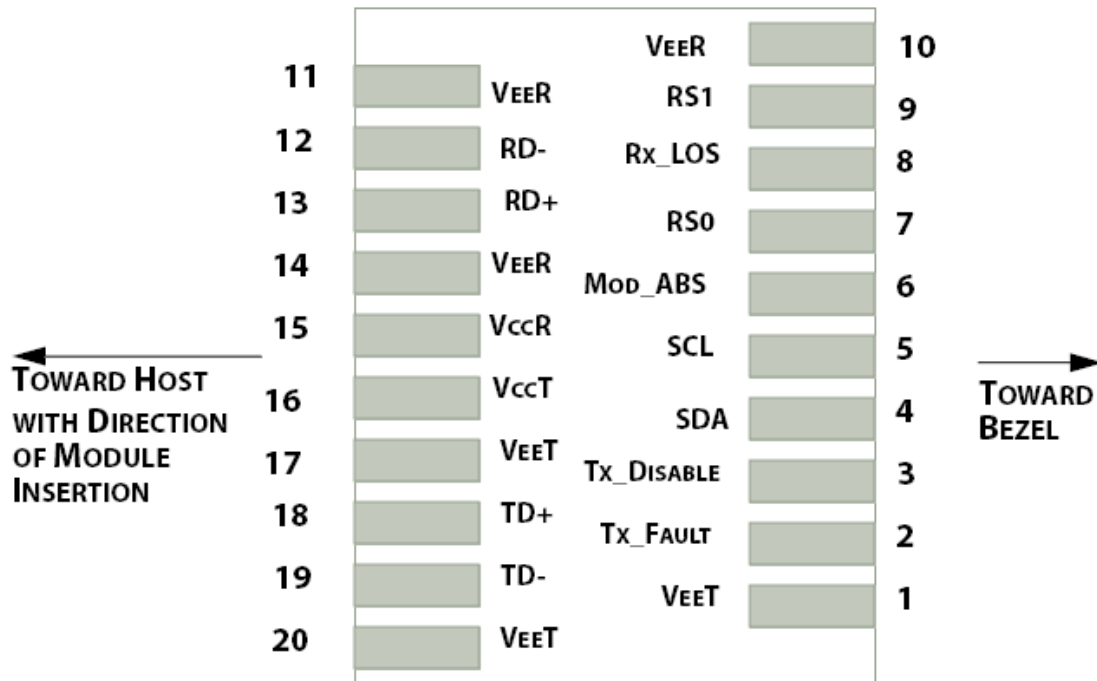

Figure2.Electrical Pin-out Details

Pin Descriptions

Pin	Symbol	Name/Description
-----	--------	------------------

1	VEET [1]	Transmitter Ground
2	Tx_FAULT [2]	Transmitter Fault
3	Tx_DIS [3]	Transmitter Disable. Laser output disabled on high or open
4	SDA [2]	2-wire Serial Interface Data Line
5	SCL [2]	2-wire Serial Interface Clock Line
6	MOD_ABS [4]	Module Absent. Grounded within the module
7	RS0 [5]	Rate Select 0
8	RX_LOS [2]	Loss of Signal indication. Logic 0 indicates normal operation
9	RS1 [5]	Rate Select 1
10	VEER [1]	Receiver Ground
11	VEER [1]	Receiver Ground
12	RD-	Receiver Inverted DATA out. AC Coupled
13	RD+	Receiver DATA out. AC Coupled
14	VEER [1]	Receiver Ground
15	VCCR	Receiver Power Supply
16	VCCT	Transmitter Power Supply
17	VEET [1]	Transmitter Ground
18	TD+	Transmitter DATA in. AC Coupled
19	TD-	Transmitter Inverted DATA in. AC Coupled
20	VEET [1]	Transmitter Ground

Notes:

[1] Module circuit ground is isolated from module chassis ground within the module.

[2].should be pulled up with 4.7k – 10k ohms on host board to a voltage between 3.15V and 3.6V.

[3]Tx_Disable is an input contact with a 4.7 kΩ to 10 kΩ pullup to VccT inside the module.

[4]Mod_ABS is connected to VeeT or VeeR in the SFP+ module. The host may pull this contact up to Vcc_Host with a resistor in the range 4.7 kΩ to 10 kΩ. Mod_ABS is asserted “High” when the SFP+ module is physically absent from a host slot.

[5] RS0 and RS1 are module inputs and are pulled low to VeeT with > 30 kΩ resistors in the module.

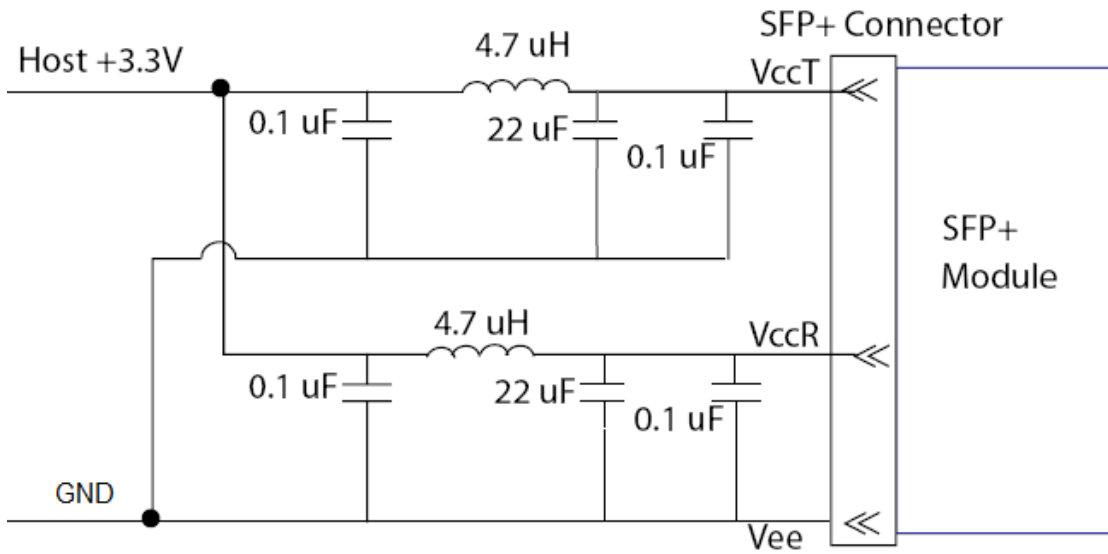

Figure3. Host Board Power Supply Filters Circuit

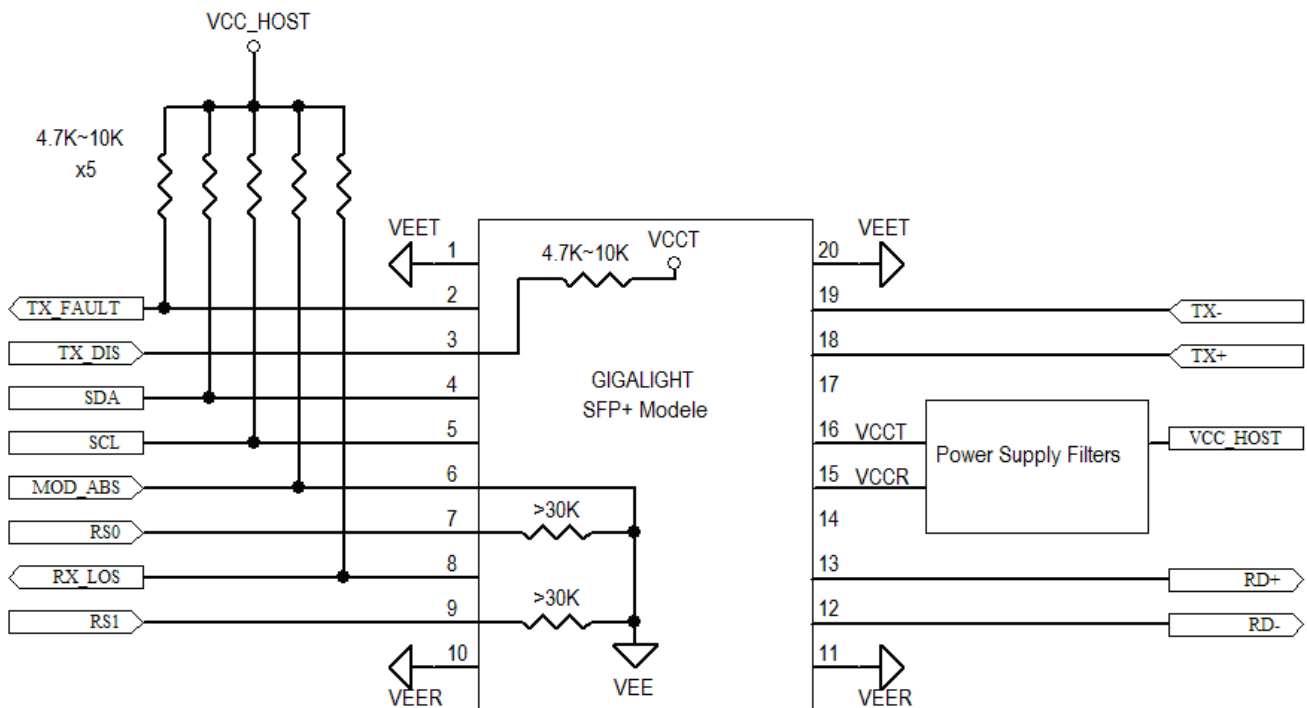

Figure4. Host-Module Interface

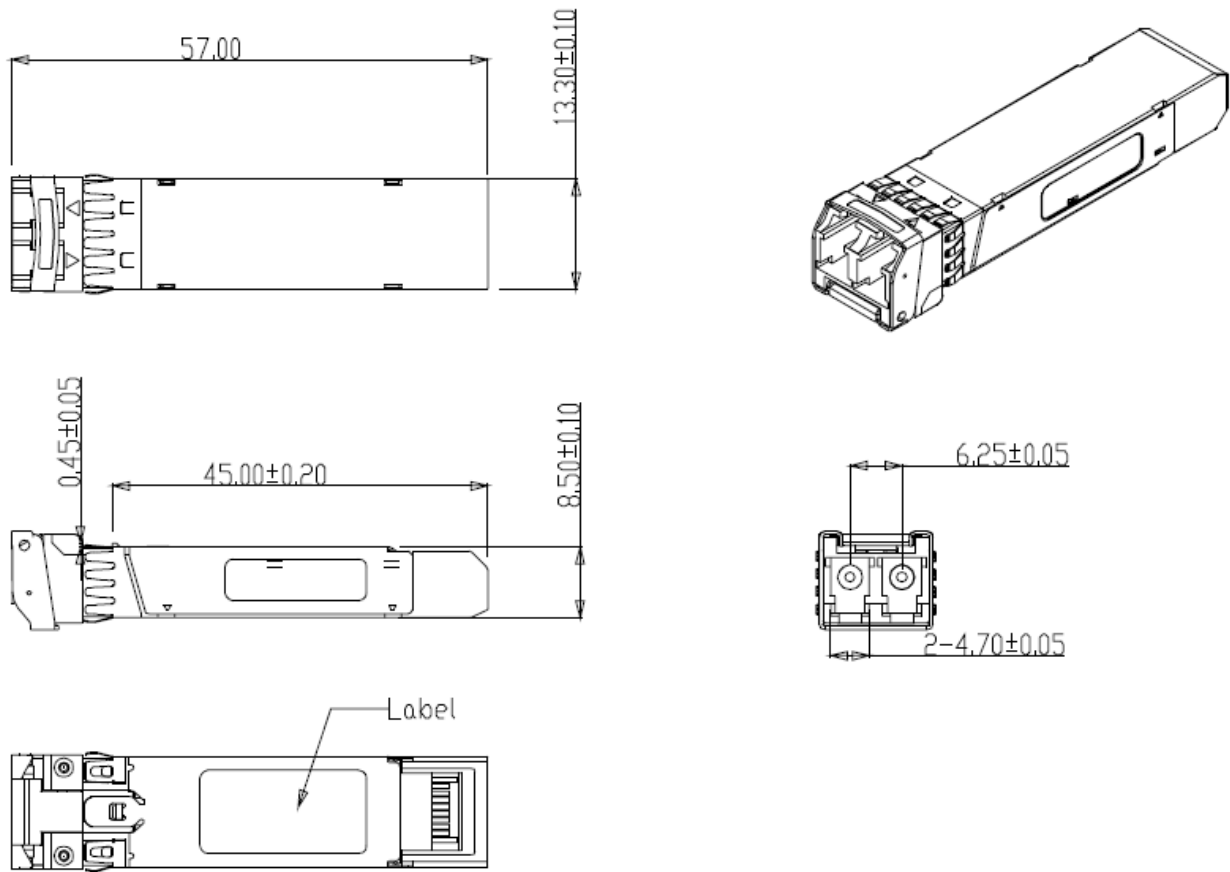

Figure5. Mechanical Specifications

Regulatory Compliance

GIGALIGHT SFP+ transceiver is designed to be Class I Laser safety compliant and is certified per the following standards:

Feature	Agency	Standard	Certificate / Comments
Laser Safety	FDA	CDRH 21 CFR 1040 and Laser Notice No. 50	1120292-000
Product Safety	UL	UL and CUL EN60950-2:2007	E347511
Environmental protection	SGS	RoHS Directive 2002/95/EC	GZ1001008918/CHEM
EMC	WALTEK	EN 55022:2006+A1:2007 EN 55024:1998+A1+A2:2003	WT10093759-D-E-E

Ordering information

Part Number	Product Description
GDP-XXX192-08C	XX= ITU Grid 18~61, 50GHz,10Gbps, DWDM SFP+ 80km, -5°C ~ +70°C

References

1. "Specifications for Enhanced Small Form Factor Pluggable Module SFP+", SFF-8431, Rev 4.1, July 6, 2009.
2. "Improved Pluggable Formfactor", SFF-8432, Rev 4.2, Apr 18, 2007
3. IEEE802.3ae – 2002
4. "Diagnostic Monitoring Interface for Optical Transceivers" SFF-8472, Rev 10.3, Dec 1, 2007

Important Notice

Performance figures, data and any illustrative material provided in this data sheet are typical and must be specifically confirmed in writing by GIGALIGHT before they become applicable to any particular order or contract. In accordance with the GIGALIGHT policy of continuous improvement specifications may change without notice.

The publication of information in this data sheet does not imply freedom from patent or other protective rights of GIGALIGHT or others. Further details are available from any GIGALIGHT sales representative.

E-mail: sales@gigalight.com.cn

Web : <http://www.gigalight.com.cn>

Revision History

Revision	Date	Description
V0	Dec. 12, 2018	Advance Release.
V1	Oct. 12. 2019	Revise ITU Grid 17~61, to Grid 18~61