

12Gbps Video SFP Optical Transmitter, 10km Reach GHTC-XX12G-L1CD

Features

- ✓ SD/HD/3G/6G/12G-SDI SFP Transmitter
- ✓ ST 259, ST 292-1, ST 424, ST-2081 and ST-2082 compatible
- ✓ Metal enclosure for Lower EMI
- ✓ DFB laser transmitter
- ✓ Supports SDI pathological patterns for SD-SDI, HD-SDI, 3G-SDI, 6G-SDI and 12G SDI
- ✓ ROHS compliant(lead free)
- ✓ single 3.3V power supply
- ✓ Hot-pluggable SFP footprint
- ✓ Operating case temperature range: 0 to +70°C



Applications

- ✓ Serial Digital Fiber Transmission System for SMPTE ST 259, SMPTE ST 344, SMPTE ST 292-1/2, SMPTE ST 424, SMPTE ST 2081-1 and SMPTE ST 2082-1 Signals
- ✓ UHDTV/HDTV/SDTV Service Interfaces

Description

Gigalight's Video transmitter is designed to transmit data rates from 50Mbps to 11.88Gbps, compliant with SMPTE ST 2082-1 (12G UHD-SDI), ST 2081-1 (6G UHD-SDI), ST424 (3G SDI), ST 292-1 (HD-SDI), and ST 259 (SD-SDI). Gigalight's Video transceiver supports SDI pathological patterns signals.

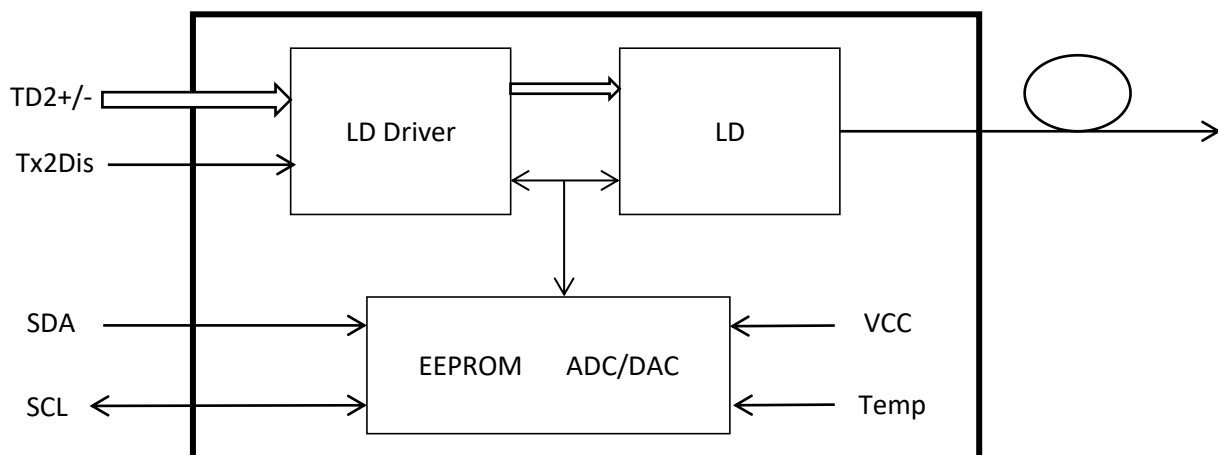

Figure 1. Module Block Diagram

Absolute Maximum Ratings

Parameter	Symbol	Min	Max	Unit
Supply Voltage	V_{CC}	-0.5	4	V
Storage Temperature	T_s	-40	+85	°C
Operating Humidity	-	5	85	%

Recommended Operating Conditions

Parameter	Symbol	Min	Typical	Max	Unit
Operating Case Temperature	T_c	0		+70	°C
Power Supply Voltage	V_{CC}	3.13	3.3	3.47	V
Power Supply Current	I_{CC}		160		mA
Data Rate			12		Gbps

Optical and Electrical Characteristics

Parameter	Symbol	Min	Typical	Max	Unit	Notes	
Transmitter							
Spectral Width (-20dB)	σ			1	nm		
Side Mode Suppression Ratio	SMSR	30			dB		
Average Output Power	P_{out}	-3		1	dBm	1	
Extinction Ratio	ER	3.5			dB		
Data Input Swing Differential	V_{IN}	400		1000	mV	2	
Input Differential Impedance	Z_{IN}	90	100	110	Ω		
Rise/Fall Time (20%~80%)	SD-SDI			1500	ps	3	
	HD-SDI			270			
	3G-SDI			135			
	6G-SDI			80			
	12G-SDI			45			
Output Jitter	Timing Jitter	SD-SDI			0.2	UI	4
		HD-SDI			1		
		3G-SDI			2		
		6G-SDI			4		
		12G-SDI			8		
	Alignment	SD-SDI			0.2		

	Jitter	HD-SDI				0.2		
		3G-SDI				0.3		
		6G-SDI				0.3		
		12G-SDI				0.3		
TX Disable	Disable		2.0		Vcc	V		
	Enable		0		0.8	V		
TX Fault	Fault		2.0		Vcc	V		
	Normal		0		0.8	V		

Note:

1. The optical power is launched into SMF.
2. PECL input, internally AC-coupled and terminated.
3. Rise and fall times, 20% to 80%,
4. UI means one period.

Diagnostics Specification

Parameter	Range	Unit	Accuracy	Calibration
Tx Disable Negate Time	0 to +70	°C	±3°C	Internal / External
Voltage	3.0 to 3.6	V	±3%	Internal / External
Bias Current	0 to 100	mA	±10%	Internal / External
TX Power	-3to +1	dBm	±3dB	Internal / External

I2C Bus Interface

The I2C bus interface uses the 2-wire serial CMOS E2PROM protocol. The serial interface meets the following specifications:

- 1.Support a maximum clock rate of 280Khz.
2. Input/Output levels comply with LVCMOS/LVTTL or compatible logics.

Low: 0 – 0.8 V

High: 2.0 – 3.3 V

Undefined: 0.8 – 2.0 V

Pin Description

Pin	Signal Name	Description	Plug Seq.	Notes
1	V _{EE}	Ground	1	
2	V _{EE}	Ground	3	
3	NC	Not Connected	3	
4	V _{EE}	Ground	3	
5	SCL	2-wire Serial Interface Clock	3	Note 2
6	SDA	2-wire Serial Interface Data Line	3	Note 2
7	V _{EE}	Ground	3	
8	NC	Not Connected	3	
9	NC	Not Connected	1	
10	NC	Not Connected	1	
11	V _{EE}	Ground	1	
12	NC	Not Connected	3	
13	NC	Not Connected	3	
14	V _{EE}	Ground	1	
15	V _{CC}	Module 3.3 V Supply	2	
16	V _{CC}	Module 3.3 V Supply	2	
17	V _{EE}	Ground	1	
18	TX+	Transmitter Non-Inverted Data Input	3	Note 3
19	TX-	Transmitter Inverted Data Input	3	Note 3
20	TX_DIS	Transmitter Disable	1	Note 1

Note:

Plug Seq.: Pin engagement sequence during hot plugging.

1. TX Disable is an input that is used to shut down the transmitter optical output. It is pulled up within the module with a 4.7k~10kΩ resistor. Its states are:

Low (0 ~ 0.8V):	Transmitter on
(0.8V~2.0V):	Undefined
High (2.0 ~ 3.46V):	Transmitter Disabled
Open:	Transmitter Disabled

2. SCL,SDA:They should be pulled up with a 4.7k~10kΩ resistor on the host board to a voltage between 3.15V and 3.6V.

SCL is the clock line of two wire serial interface for serial ID.

SDA is the data line of two wire serial interface for serial ID.

3. TX-/+ : These are the differential transmitter inputs. They are internally AC-coupled, differential lines with 100Ω differential termination inside the module.

Pin Definition

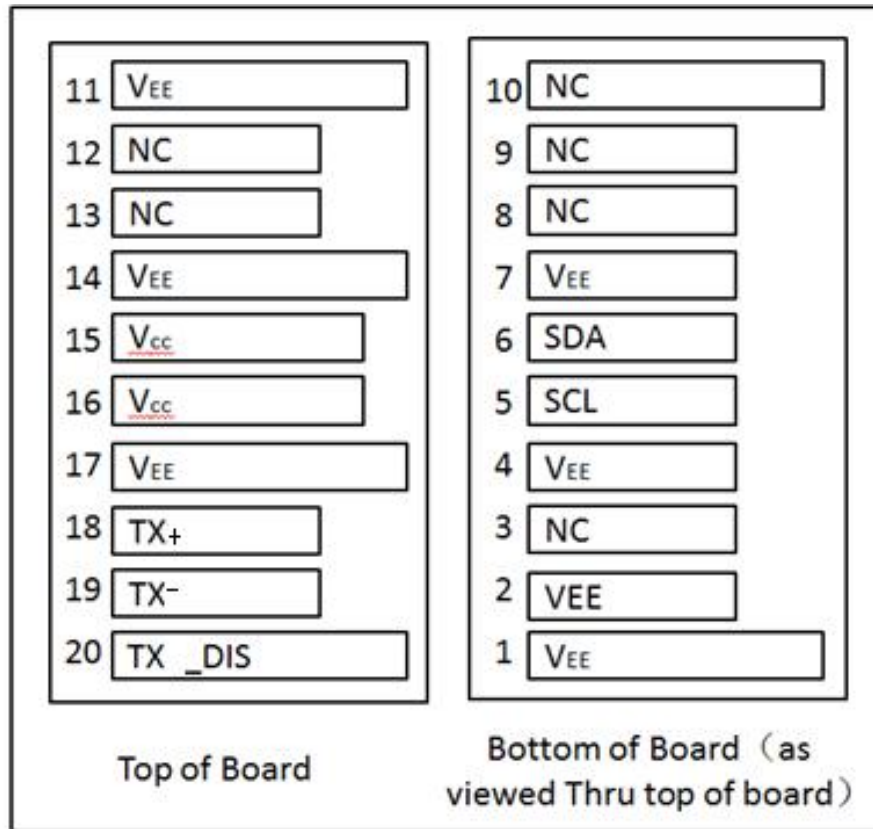

Figure 2. Electrical Pin-out Details

CWDM Wavelength(0~70°C)

Band	Suffix	Wavelength (nm)
0-band Original	A	1270
	B	1290
	C	1310
	D	1330
	E	1350
E-band Extended	F	1370
	G	1390
	H	1410
	I	1430
	J	1450

Mechanical Dimensions

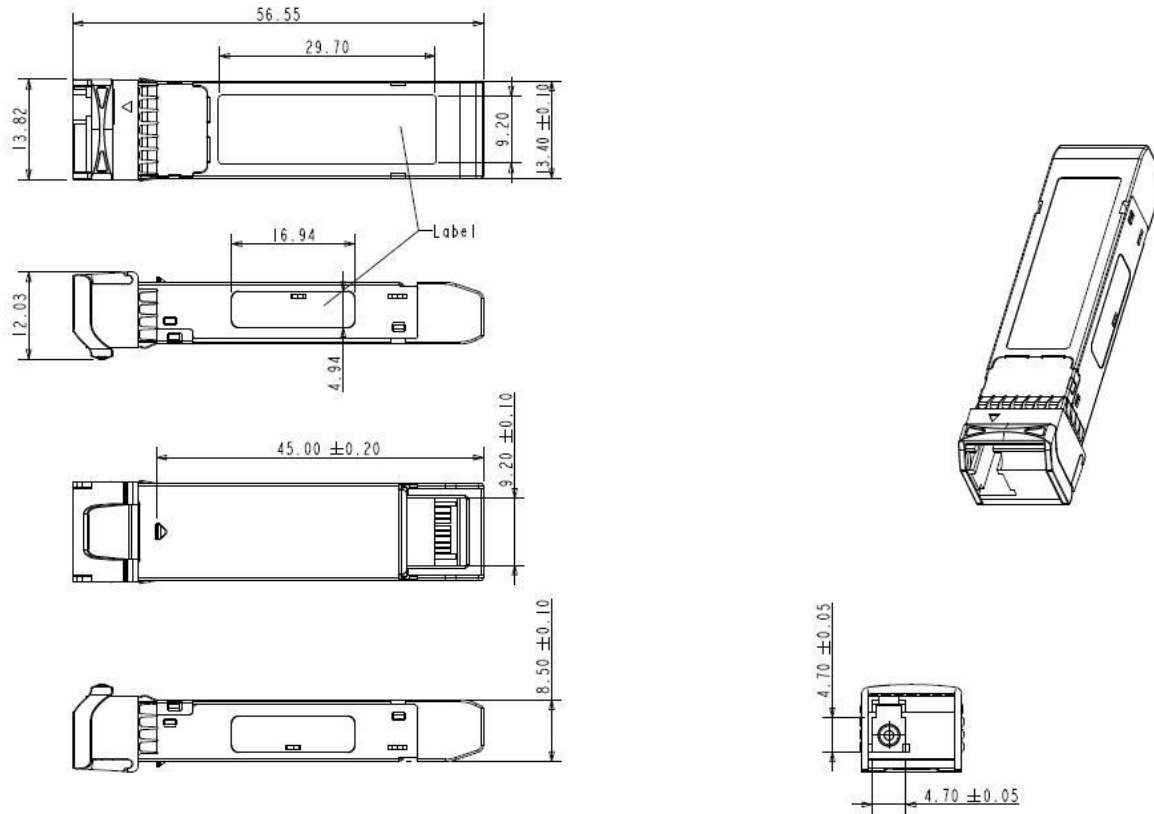

Figure 3. Mechanical Specifications

Regulatory Compliance

Feature	Standard
Laser Safety	IEC 60825-1:2014 (Third Edition)
Environmental protection	2011/65/EU
CE EMC	EN55032: 2015 EN55035: 2017 EN61000-3-2:2014 EN61000-3-3:2013
FCC	FCC Part 15, Subpart B; ANSI C63.4-2014
Product Safety	EN/UL 60950-1, 2nd Edition, 2014-10-14

CAUTION:

Use of controls or adjustment or performance of procedures other than those specified herein may result in hazardous radiation exposure.

Ordering Information

Part Number	Product Description
GHTC-XX12G-L1CD	1270~1450nm CWDM,10km,SD/HD/3G/6G/12G SDI Single Transmitter, NON-MSA

Important Notice

Performance figures, data and any illustrative material provided in this data sheet are typical and must be specifically confirmed in writing by Gigalight before they become applicable to any particular order or contract.

In accordance with the Gigalight policy of continuous improvement specifications may change without notice.

The publication of information in this data sheet does not imply freedom from patent or other protective rights of Gigalight or others. Further details are available from any Gigalight sales representative.

E-mail: sales@gigalight.com

Official Site: www.gigalight.com

Revision History

Revision	Date	Description
V0	May-27- 2020	Advance Release.
V1	Mar-21-2022	Update support wavelength