

## 1.25Gbps SFP Rugged Optical Transceiver, 550m Reach GPF-8524-S5TD

### Features

- ✓ Data-rate of 1.25Gbps operation
- ✓ 850nm VCSEL laser and PIN photodetector
- ✓ Compliant with SFP MSA and SFF-8472 with duplex LC receptacle
- ✓ Digital Diagnostic Monitoring: Internal Calibration or External Calibration
- ✓ 550m transmission with 50/125 $\mu$ m MMF
- ✓ 300m transmission with 62.5/125 $\mu$ m MMF
- ✓ Compatible with RoHS
- ✓ +3.3V single power supply
- ✓ Operating case temperature: industrial : -40 to +85 $^{\circ}$ C
- ✓ Parylene and conformal coating on PCBA and OSA barrel



### Applications

- ✓ Gigabit Ethernet
- ✓ Fiber Channel
- ✓ Switch to Switch interface
- ✓ Switched backplane applications
- ✓ Router/Server interface
- ✓ Other optical transmission systems
- ✓ Rugged environment use(Anti-mold, Anti-moisture, Anti-salt spray)

### Description

GPF-8524-S5TD is high performance, cost effective modules supporting data-rate of 1.25Gbps and 550m transmission distance with MMF, it is compatible with SFP Multi-Source Agreement (MSA) and SFF-8472. For further information, please refer to SFP MSA.

GPF-8524-S5TD is designed for moisture and corrosion protection of printed circuit boards and electronic components, this product contains parylene and conformal coating so it's especially suitable for rugged environment .

### Module Block Diagram

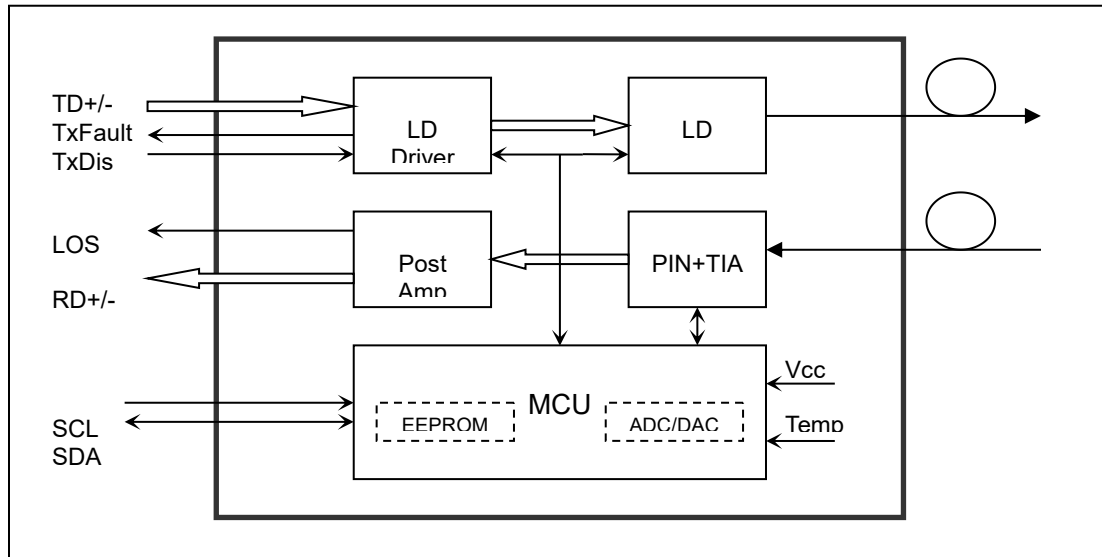

## Absolute Maximum Ratings

Table 1 - Absolute Maximum Ratings

Parameter	Symbol	Min	Max	Unit
Supply Voltage	Vcc	-0.5	4.5	V
Storage Temperature	Ts	-40	+85	°C
Operating Humidity	-	5	85	%

## Parylene and conformal coating parameter

Table 2 - Parylene and conformal coating parameter

Parameter	Symbol	Min	Typical	Max	Unit
Parylene Thickness	Pt		20		um
Parylene Hardness	Ph		R80		
Strength of extension	Se		70		Mpa

## Recommended Operating Conditions

Table 3 - Recommended Operating Condition

Parameter	Symbol	Min	Typical	Max	Unit
Operating Case Temperature	Tc	-40		+85	°C
Power Supply Voltage	Vcc	3.13	3.3	3.47	V
Power Supply Current	Icc			300	mA

Data Rate			1.25		Gbps
-----------	--	--	------	--	------

## Optical and Electrical Characteristics

GPF-8524-S5TD: (VCSEL and PIN, 500m Reach)

Table 4 - Optical and Electrical Characteristics

Parameter	Symbol	Min	Typical	Max	Unit	Notes
<b>Transmitter</b>						
Centre Wavelength	$\lambda_c$	830	850	860	nm	
Spectral Width (RMS)	$\Delta\lambda$			0.85	nm	
Average Output Power	P <sub>out</sub>	-9.5		-3.5	dBm	1
Extinction Ratio	ER	9			dB	
Optical Rise/Fall Time (20%~80%)	tr/tf			0.26	ns	
Data Input Swing Differential	V <sub>IN</sub>	400		1800	mV	2
Input Differential Impedance	Z <sub>IN</sub>	90	100	110	$\Omega$	
TX Disable	Disable		2.0	V <sub>cc</sub>	V	
	Enable		0	0.8	V	
TX Fault	Fault		2.0	V <sub>cc</sub>	V	
	Normal		0	0.8	V	
<b>Receiver</b>						
Centre Wavelength	$\lambda_c$	770		860	nm	
Receiver Sensitivity				-18	dBm	3
Receiver Overload		0			dBm	3
LOS De-Assert	LOS <sub>D</sub>			-18	dBm	
LOS Assert	LOS <sub>A</sub>	-35			dBm	
LOS Hysteresis		1		4	dB	
Data Output Swing Differential	V <sub>out</sub>	400		1800	mV	4
LOS	High	2.0		V <sub>cc</sub>	V	
	Low			0.8	V	

### Notes

1. The optical power is launched into MMF.

2. PECL input, internally AC-coupled and terminated.
3. Measured with a PRBS 2<sup>7</sup>-1 test pattern @1250Mbps, BER ≤1×10<sup>-12</sup>.
4. Internally AC-coupled.

## Timing and Electrical

Table 5 - Timing and Electrical

Parameter	Symbol	Min	Typical	Max	Unit
Tx Disable Negate Time	t_on			1	ms
Tx Disable Assert Time	t_off			10	μs
Time To Initialize, including Reset of Tx Fault	t_init			300	ms
Tx Fault Assert Time	t_fault			100	μs
Tx Disable To Reset	t_reset	10			μs
LOS Assert Time	t_loss_on			100	μs
LOS De-assert Time	t_loss_off			100	μs
Serial ID Clock Rate	f_serial_cloc k			400	KHz
MOD_DEF (0:2)-High	V <sub>H</sub>	2		V <sub>cc</sub>	V
MOD_DEF (0:2)-Low	V <sub>L</sub>			0.8	V

## Diagnostics

Table 6 – Diagnostics Specification

Parameter	Range	Unit	Accuracy	Calibration
Temperature	0 to +70	°C	±3°C	Internal / External
	-20 to +85			
Voltage	3.0 to 3.6	V	±3%	Internal / External
Bias Current	0 to 100	mA	±10%	Internal / External
TX Power	-9.5 to -3.5	dBm	±3dB	Internal / External
RX Power	-18 to -3	dBm	±3dB	Internal / External

## Digital Diagnostic Memory Map

The transceivers provide serial ID memory contents and diagnostic information about the present operating

conditions by the 2-wire serial interface (SCL, SDA).

The diagnostic information with internal calibration or external calibration all are implemented, including received power monitoring, transmitted power monitoring, bias current monitoring, supply voltage monitoring and temperature monitoring.

The digital diagnostic memory map specific data field defines as following.

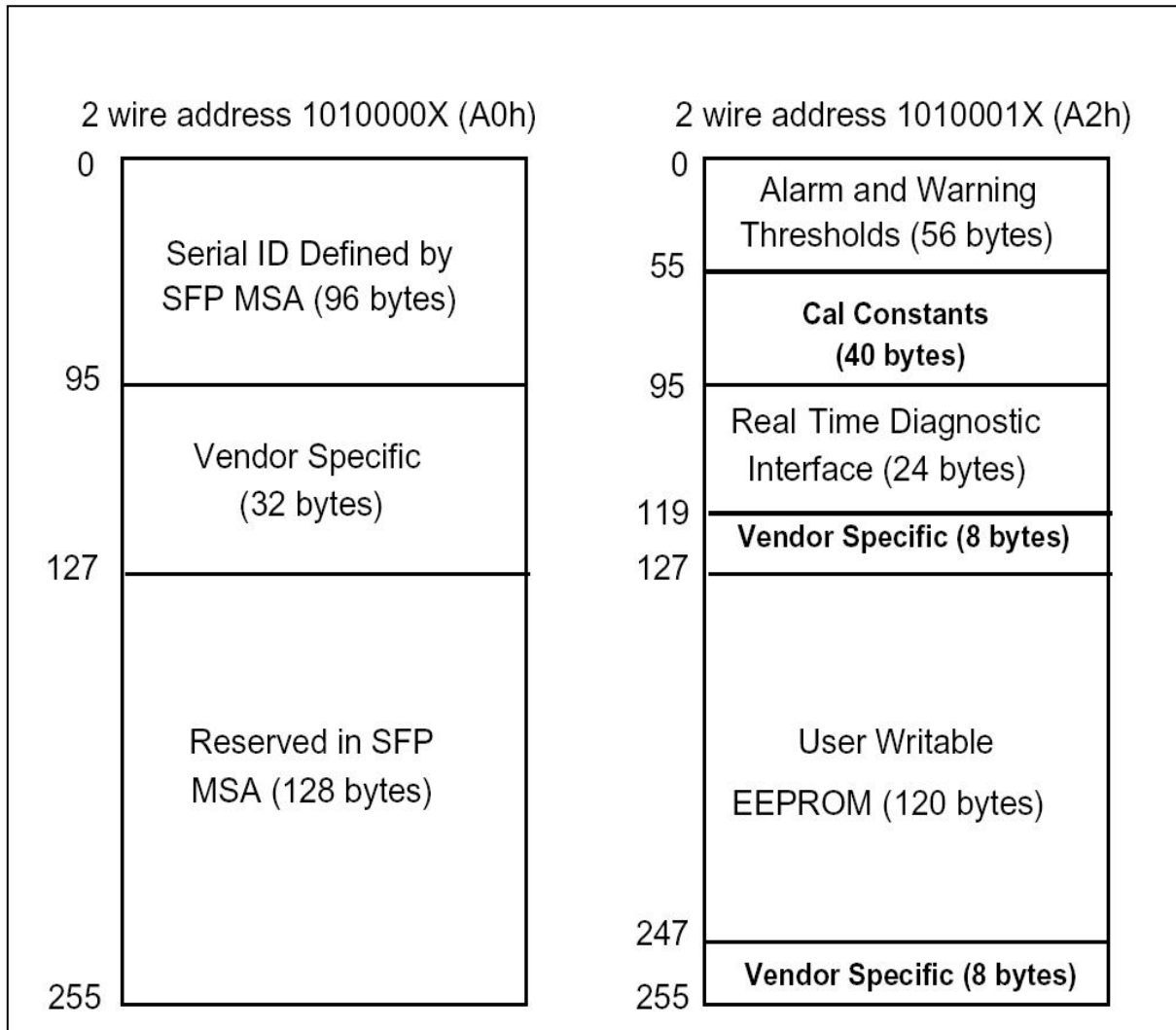

## Pin Definitions

### Pin Diagram

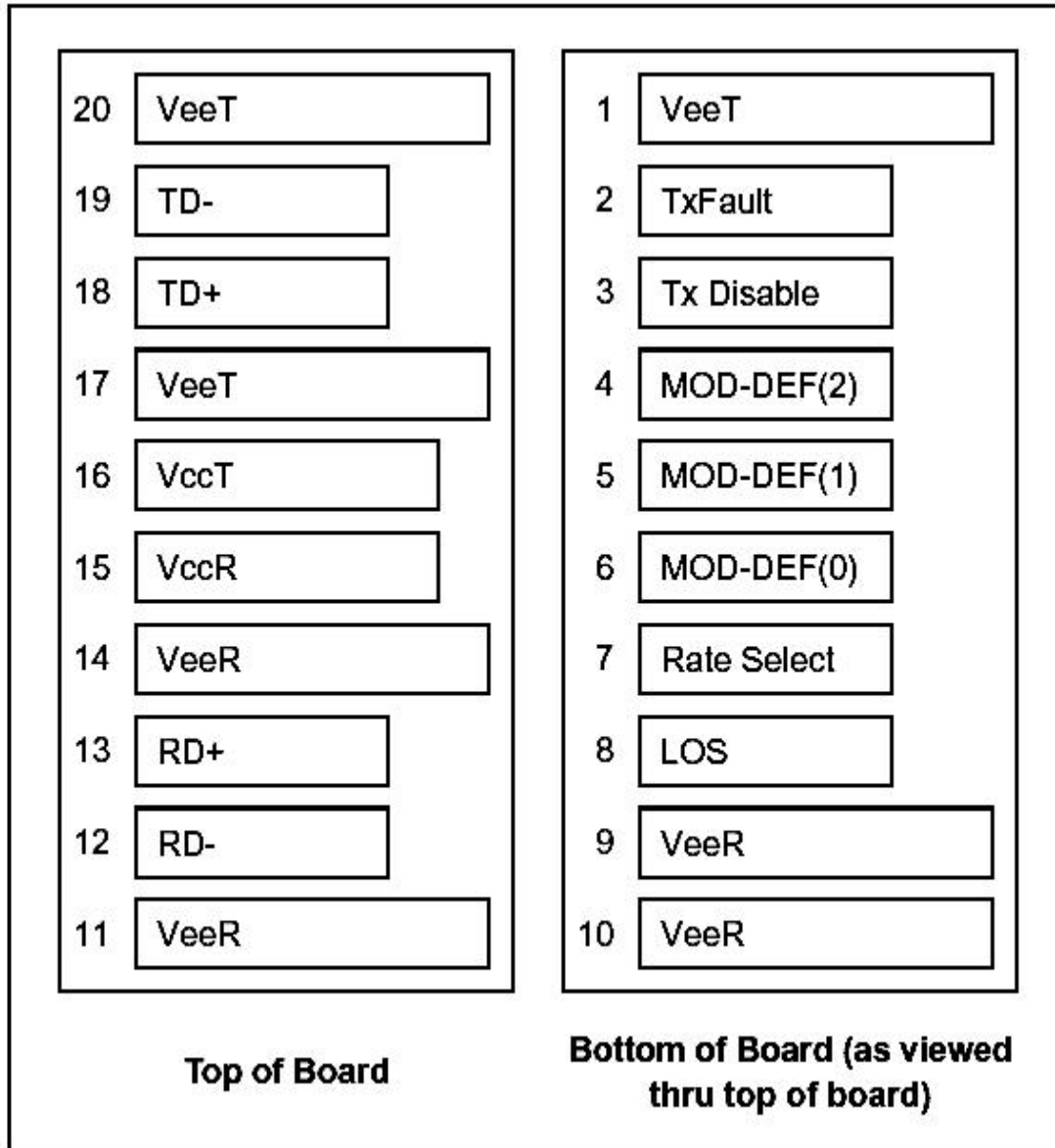

## Pin Descriptions

Pin	Signal Name	Description	Plug Seq.	Notes
1	V <sub>EET</sub>	Transmitter Ground	1	
2	TX FAULT	Transmitter Fault Indication	3	Note 1
3	TX DISABLE	Transmitter Disable	3	Note 2

4	MOD_DEF(2)	SDA Serial Data Signal	3	Note 3
5	MOD_DEF(1)	SCL Serial Clock Signal	3	Note 3
6	MOD_DEF(0)	TTL Low	3	Note 3
7	Rate Select	Not Connected	3	
8	LOS	Loss of Signal	3	Note 4
9	V <sub>EER</sub>	Receiver ground	1	
10	V <sub>EER</sub>	Receiver ground	1	
11	V <sub>EER</sub>	Receiver ground	1	
12	RD-	Inv. Received Data Out	3	Note 5
13	RD+	Received Data Out	3	Note 5
14	V <sub>EER</sub>	Receiver ground	1	
15	V <sub>CCR</sub>	Receiver Power Supply	2	
16	V <sub>CCT</sub>	Transmitter Power Supply	2	
17	V <sub>EET</sub>	Transmitter Ground	1	
18	TD+	Transmit Data In	3	Note 6
19	TD-	Inv. Transmit Data In	3	Note 6
20	V <sub>EET</sub>	Transmitter Ground	1	

**Notes:**

Plug Seq.: Pin engagement sequence during hot plugging.

- 1) TX Fault is an open collector output, which should be pulled up with a 4.7k~10kΩ resistor on the host board to a voltage between 2.0V and V<sub>cc</sub>+0.3V. Logic 0 indicates normal operation; Logic 1 indicates a laser fault of some kind. In the low state, the output will be pulled to less than 0.8V.
- 2) TX Disable is an input that is used to shut down the transmitter optical output. It is pulled up within the module with a 4.7k~10kΩ resistor. Its states are:
 

Low (0 to 0.8V):	Transmitter on
(>0.8V, < 2.0V):	Undefined
High (2.0 to 3.465V):	Transmitter Disabled
Open:	Transmitter Disabled
- 3) Mod-Def 0,1,2. These are the module definition pins. They should be pulled up with a 4.7k~10kΩ resistor on the host board. The pull-up voltage shall be V<sub>ccT</sub> or V<sub>ccR</sub>.  
Mod-Def 0 is grounded by the module to indicate that the module is present

Mod-Def 1 is the clock line of two wire serial interface for serial ID

Mod-Def 2 is the data line of two wire serial interface for serial ID

- 4) LOS is an open collector output, which should be pulled up with a 4.7k~10kΩ resistor. Pull up voltage between 2.0V and Vcc+0.3V. Logic 1 indicates loss of signal; Logic 0 indicates normal operation. In the low state, the output will be pulled to less than 0.8V.
- 5) RD-/+ : These are the differential receiver outputs. They are internally AC-coupled 100 differential lines which should be terminated with 100Ω (differential) at the user SERDES.
- 6) TD-/+ : These are the differential transmitter inputs. They are internally AC-coupled, differential lines with 100Ω differential termination inside the module.

### Recommended Interface Circuit

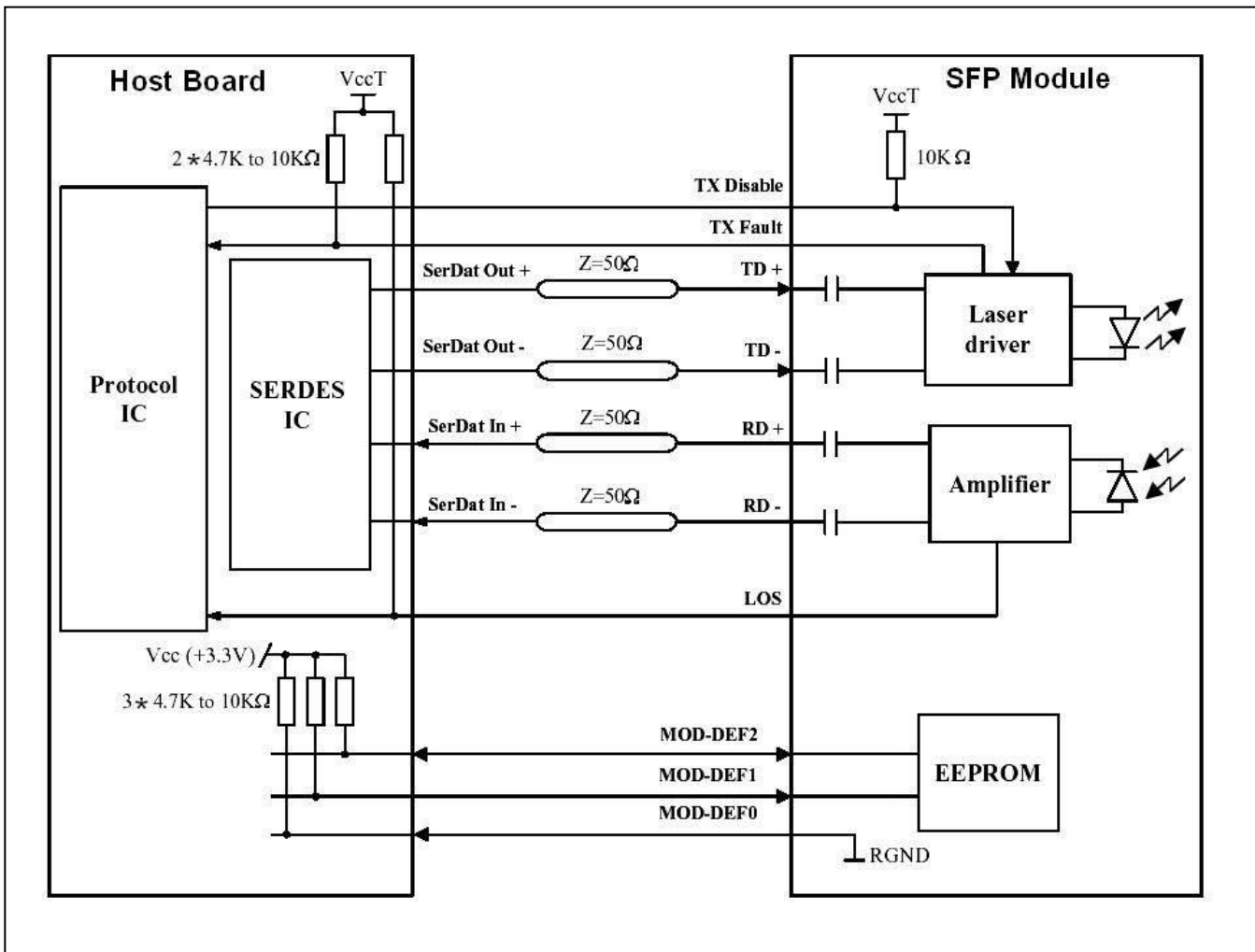



### Mechanical Dimensions

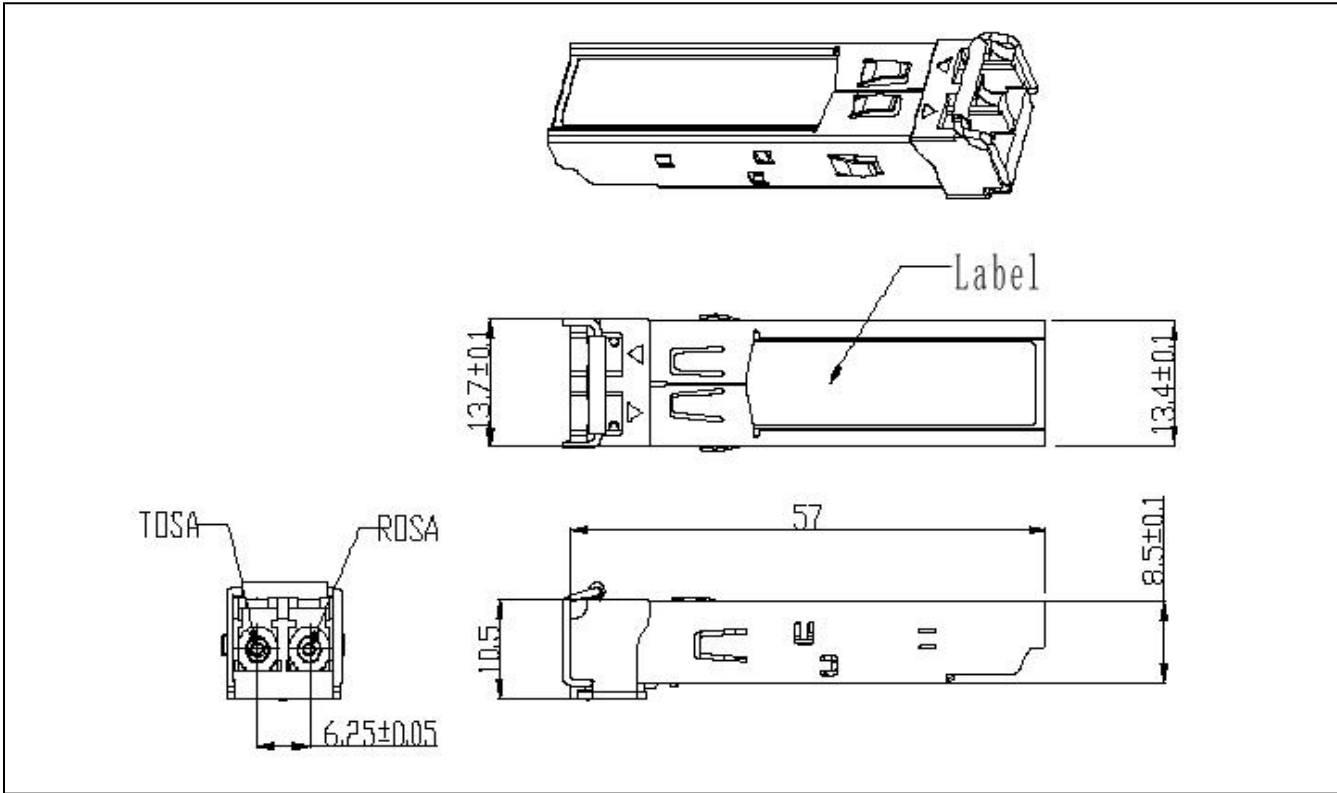

### Parylene and conformal coating area

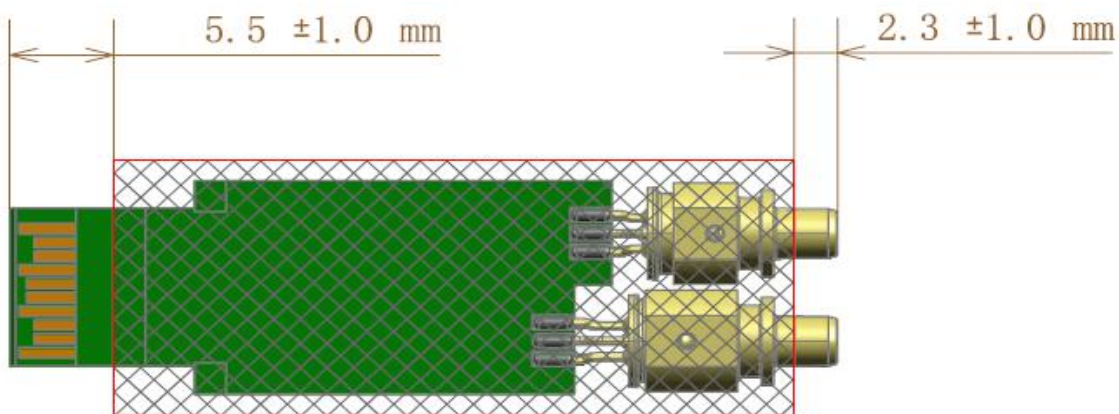

### Regulatory Compliance

GIGALIGHT SFP transceiver is designed to be Class I Laser safety compliant and meet the requirements of the following standards.

Feature	Standard
Laser Safety	IEC 60825-1:2014 (3 <sup>rd</sup> Edition) IEC 60825-2:2004/AMD2:2010 EN 60825-1:2014 EN 60825-2:2004+A1+A2
Electrical Safety	EN 62368-1: 2014 IEC 62368-1:2014 UL 62368-1:2014
Environmental protection	Directive 2011/65/EU with amendment(EU)2015/863
CE EMC	EN55032: 2015 EN55035: 2017 EN61000-3-2:2014 EN61000-3-3:2013
FCC	FCC Part 15, Subpart B ANSI C63.4-2014

## Ordering information

Part Number	Product Description
GPF-8524-S5TD	850nm, 1.25Gbps, 550m, -40°C ~ +85°C, With Digital Diagnostic Monitoring With Parylene and conformal coating

## References

1. Small Form Factor Pluggable (SFP) Transceiver Multi-Source Agreement (MSA),September 2000.
2. Telcordia GR-253-CORE and ITU-T G.957 Specifications.

## Important Notice

Performance figures, data and any illustrative material provided in this data sheet are typical and must be specifically confirmed in writing by GIGALIGHT before they become applicable to any particular order or contract. In accordance with the GIGALIGHT policy of continuous improvement specifications may change without notice.

The publication of information in this data sheet does not imply freedom from patent or other protective rights of GIGALIGHT or others. Further details are available from any GIGALIGHT sales representative.

E-mail: [sales@gigalight.com.cn](mailto:sales@gigalight.com.cn)

Official Site: <http://www.gigalight.com.cn>

## Revision History

Revision	Date	Description
V0	Jun-27-2022	Advance Release.
V1	July-5-2022	Update the tolerance of parylene and conformal coating area to 1mm from 0.5mm