

Gigalight 200GE to 4X56G QSFP56(QSFP56 to 4xSFP56)

Direct Attach Cable

P/N: GQS-4Q56-PXXC

Features

- ✓ 1 QSFP56 and 4X SFP56 breakout form factor
- ✓ 26~30AWG support up to 3m length max
- ✓ Maximum aggregate data rate: 200Gb/s
- ✓ I2C interface for EEPROM signature which can be customized and CMIS V4.0 compliant
- ✓ Operating Temperature: 0~ 70 °C
- ✓ ROHS Compliant



Applications

- ✓ 40GE/100GE/200GE
- ✓ Infiniband QDR/FDR/EDR/HDR
- ✓ Data storage and communication industry
- ✓ Switch / router / HBA
- ✓ Enterprise network
- ✓ Data Center Network

STANDARDS COMPLIANCE

- ✓ IEEE 802.3bj&IEEE802.3cd
- ✓ 100GEBASE-CR4&200GBASE-CR4
- ✓ InfiniBand architecture

Product Description

Gigalight's GQS-4Q56-PXXC cable assembly is high performance, cost effective I/O solutions for LAN, HPC and SAN. The passive cable assembly connects data signals from each of the 8 pairs on the single QSFP56 end to the 4 SFP56 multiport ends.

The high speed cable assembly meets and exceeds 200 Gigabit Ethernet, InfiniBand EDR /HDR and

temperature requirements for performance and reliability.

Recommended Operating Conditions

Parameter	Symbol	Min	Typical	Max	Unit
Storage Ambient Temperature		-40		+85	°C
Operating Case Temperature	T _c	0		+70	°C
Power Supply Voltage	V _{CC3}	3.14	3.3	3.47	V
Data Rate Per Lane		1		28	GBaud/s

Differential Impedance

Parameter	Symbol	Min	Typical	Max	Unit
Differential Impedance(bulk cable)	R _{in1} ,P-P	95	100	110	Ω
Differential Impedance (Mated connector)	R _{in2} ,P-P	90	100	110	Ω
Differential Impedance(cable termination)	R _{in3} ,P-P	85	100	110	Ω

PCB Contact Configuration

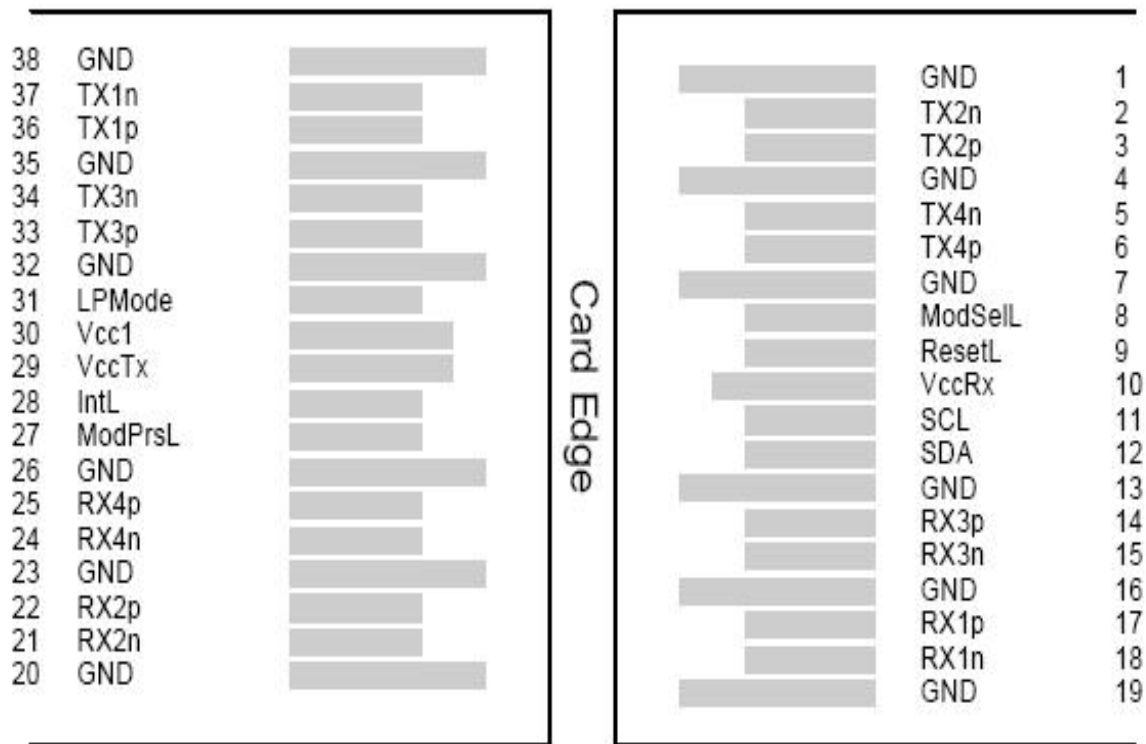

ELECTRICAL

Item	Specification
Low Level Contact Resistance	Initial: Baseline, with 75mm cable from the backshell edge. Change : 20 milliohms maximum
Insulation Resistance (Raw cable)	100VDC, 1000Mohm (Min.)
Dielectric Withstanding Voltage	AC 300V 1min, no breakdown or flash

SIGNAL INTEGRITY

A	Time domain parameter	Test condition	SPEC	Equipment
1	Differential Impedance(bulk cable)	TDR Tr:25ps	100+10/-5ohms	E5071C or DSA830 0
2	Differential Impedance (Mated connector)		100+10/-10ohms	
3	Differential Impedance(cable termination)		100+10/-15ohms	
4	Intra-skew		L*15+20	

B	Frequency domain parameter	Test condition	Test spec(dB)	f(GHz)	
1	SDD11/SD D22	Freq:50MHz ~20GHz Points:1601	$-22+20/25.78*f*10^{(-3)}$	0.05≤f<4.1	E5071C
			$-10.66+14*\log((f*10^{(-3)})/5.5)$ ≤5.3dB@13.26GHz	4.1≤f≤19	
2	SCC11/SC C22	Freq:50MHz ~20GHz Points:1601	≤-2dB	0.2≤f≤19	
3	SDC11/SD C22	Freq:50MHz ~20GHz Points:1601	$-16+2*f/3$	0.05≤f≤2	
4	SCD21-SDD21	Freq:50MHz ~20GHz Points:1601	10 as 0.01≤f < 12.89	0.01≤f≤19	
			$-27+29/22*f*0.001$ 6.3 as 15.7≤f≤19		
5	MDNEXT	Freq:50MHz ~20GHz Points:1601	≤-26dB@12.89GHz	0.01≤f≤19	
6	SDD21	Freq:50MHz ~20GHz Points:1601 IF: 1KHz	$-0.7*(f*10^{(-3)})^{0.5}-0.3*(f*10^{(-3)})-$ $0.01*(f*10^{(-3)})^2$ <17.16dB@13.26GHz	0.01≤f≤19	
7	COM	IEEE802.3cd	>3dB		

MNICAL

Item	Specification
Mating Force	40N Max. With retention latch disengaged.
Un-mating Force	30N Max. With retention latch disengaged.
Latch retention force	90N Min.
Durability	250 cycles

Mechanical Dimensions

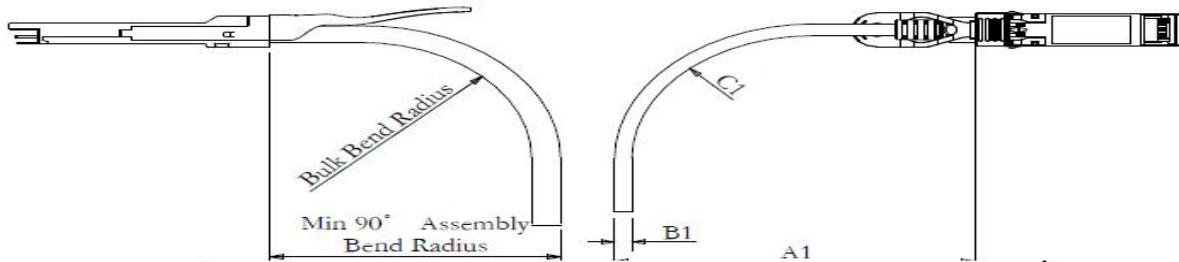
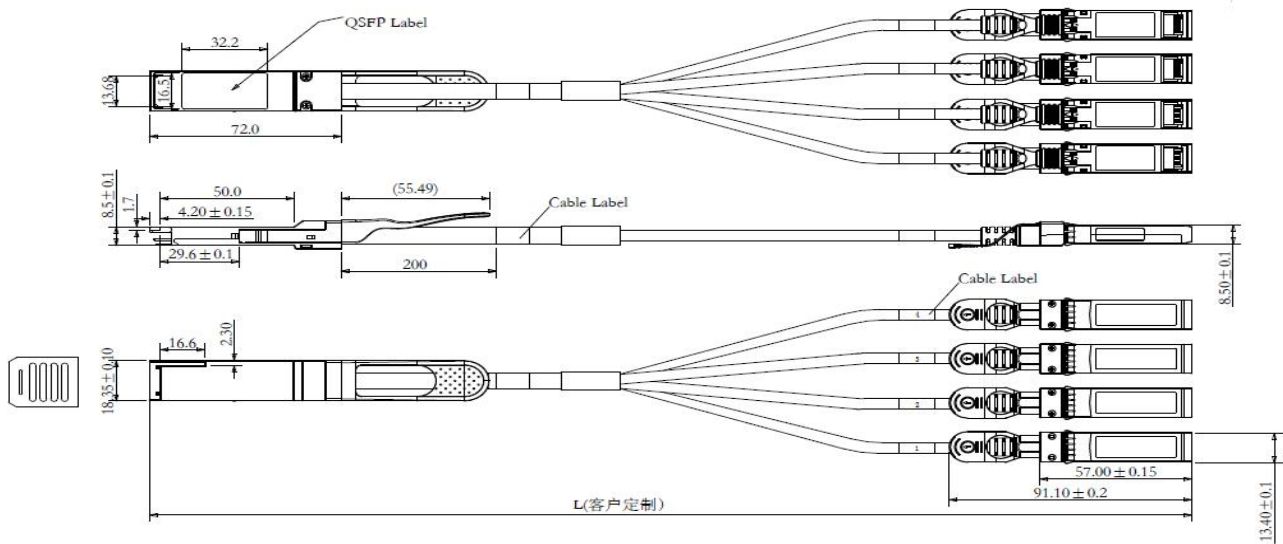

SFP56			
CABLE GAUGE	DIAMETER "B1"	MIN. BEND RADIUS "C1"	MIN. BEND RADIUS "A1"
26AWG	4.8MM	24MM	65MM

L (m)	Tolerance (cm)	Type	Cable Dia. (mm)	Dynamic (mm)	Static (mm)	Assembly Min Bend Radius (mm)
0.5 ≤ L < 3	± 5	30AWG	6.9 ± 0.3	72	36	63
3 ≤ L ≤ 5	± 8	26AWG	8.4 ± 0.3	90	45	74

Wiring connection diagram

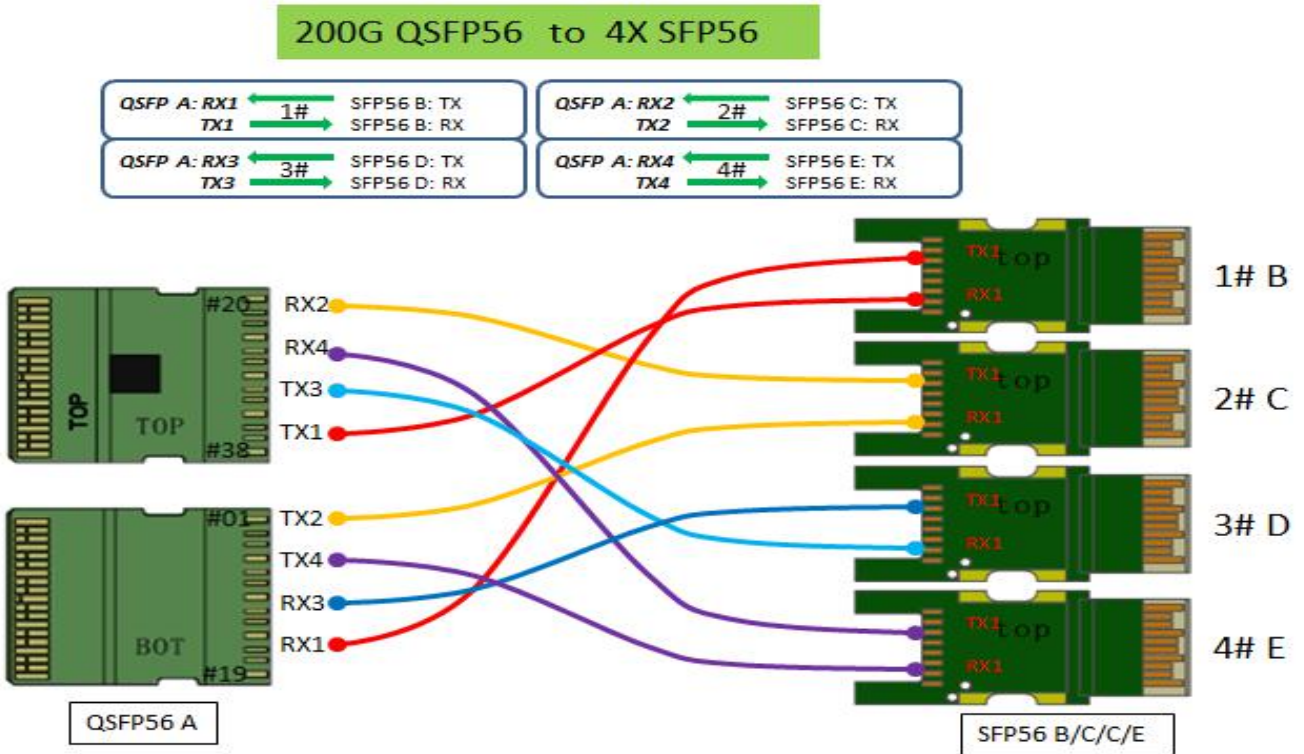

ENVIRONMENTAL

Item	Specification
Physical shock	Subject mated specimens to 30G's half-sine shock pulses of 11 milliseconds duration. 3 shocks in each direction applied along 3 mutually perpendicular planes, 18 total shocks
Vibration (random)	Subject mated specimens to 3.10G's rms between 20-500 Hz for 15 minutes in each of 3 mutually perpendicular planes
Thermal shock	100 cycles of: a) -55°C for 30 minutes b) +85°C for 30 minutes
Temperature Life	Subject mated Specimens to +105°C for 500 hours
Humidity and Temperature cycling	Subject unmated specimens to 10 cycles (10 days) between 25 and 65°C at 80% to 100% RH
Visual Examination.	Connectors & contacts shall have no evidence of physical defects or otherwise unfit for testing.

Regulatory Compliance

Gigalight GQS-4Q56-PXXC passive cable assembly meets the requirements of the following standards:

Feature	Standard
Electrical Safety	EN 62368-1: 2014 IEC 62368-1:2014 UL 62368-1:2014
Environmental protection	Directive 2011/65/EU with amendment(EU)2015/863
CE EMC	EN55032: 2015 EN55035: 2017 EN61000-3-2:2014 EN61000-3-3:2013
FCC	FCC Part 15, Subpart B; ANSI C63.4-2014

Ordering information

Part Number	GQS-4Q56--PXXC		
Length (meter)	1	2	3
Wire gauge (AWG)	30	30	26

Example:

GQS-4Q56-P01C/30AWG

GQS-4Q56-P03C/26AWG

Important Notice

Performance figures, data and any illustrative material provided in this data sheet are typical and must be specifically confirmed in writing by GIGALIGHT before they become applicable to any particular order or contract. In accordance with the GIGALIGHT policy of continuous improvement specifications may change without notice.

The publication of information in this data sheet does not imply freedom from patent or other protective rights of GIGALIGHT or others. Further details are available from any GIGALIGHT sales representative.

sales@gigalight.com.cn
<http://www.gigalight.com>



Revision History

Version	Date	Description
V0	Apr-22-2023	Advance Release.