

GIGALIGHT 200G QSFP56 immersion cooling extender

P/N: GLQE-PC201-DXX



Features

- ✓ Compliant QSFP MSA
- ✓ Typical insertion loss less 5dB@13.28GHz
- ✓ 100ohm differential impedance system
- ✓ 3.3V power supply
- ✓ I2C R/W function
- ✓ Status indicators with LED
- ✓ Low EMI radiation and crosstalk
- ✓ RoHS 6 compliant(lead free)

Applications

- ✓ Extend 200G/100G/40G transceiver/AOC for liquid immersion link environment
- ✓ Protect device QSFP SMT connector
- ✓ provide I2C R/W and some status indicators with LED

Description

Gigalight can offer rich experience of immersion solution, that includes different form and speed transceivers/AOC product. Gigalight 200G QSFP56 immersion cooling extender (GLQE-PC201-DXX) is an important part of liquid immersion solution, normal QSFP form transceiver/AOC can be used for immersion environment with this product. This product include extender cage, cable, QSFP housing three parts, the cable length can be customized no more than 0.5m for extension, that can avoid the optical lens/engine/interface

exposure to the liquid indirectly.

In addition, this product can provide I2C read/write, also can show the status indicators with LED for low speed electrical hardware pins. When insertion and removal frequently, this product can effectively protect the QSFP SMT connector of switch/NIC.

Liquid cooling Advantage

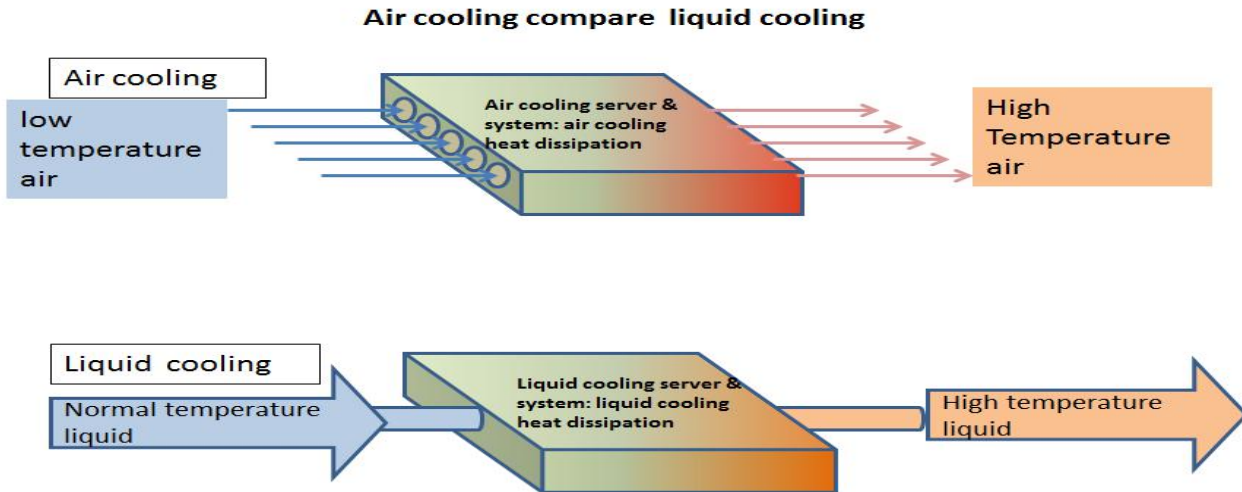

Figure 1. Liquid cooling advantage

As the requirement of data traffic keeping growth and the heat flux emitted by datacenter internal chips increases constantly, traditional air cooling methods are under pressure. Liquid cooling technologies removes the heat more efficiently with dielectric fluids that have high heat capacity to improve the efficiency of energy in datacenter.

Gigalight solved the lack of optical transceivers which perform reliability in immersion even liquid immersion depth up to 10m, the Liquid cooling optical series transceiver is suitable for liquid cooling server & system, this series product are compatible with fluorinated liquid and mineral oils well.

Immersion cooling extender can also be a important role in liquid immersion solution, existing normal QSFP form transceiver/AOC can be adapted for immersion indirectly.

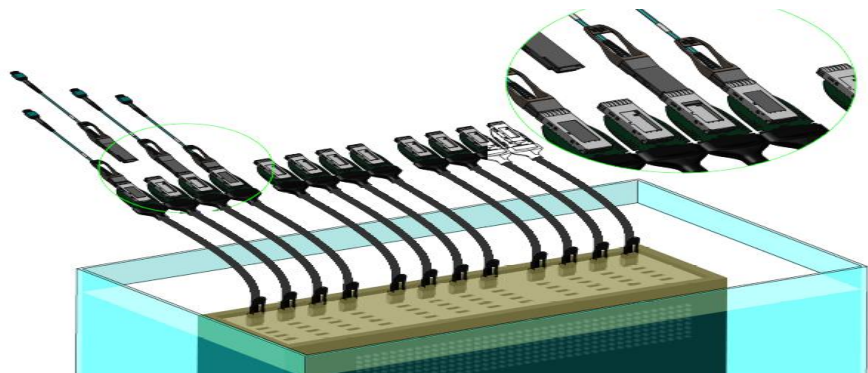

Figure 2 QSFP56 immersion cooling extender under liquid

Absolute Maximum Ratings

Parameter	Symbol	Min	Max	Unit
Storage Temperature	T _s	-20	85	°C
Case Operating Temperature	T _c	0	70	°C
Humidity (non-condensing)	Rh	5	95	%

Recommended Operating Conditions

Parameter	Symbol	Min	Typical	Max	Unit
Operating Case Temperature	T _c	-20		70	°C
Baud Rate per Lane	fd		26.56		GBaud/s
Humidity	Rh	5		85	%

Main Part assembly

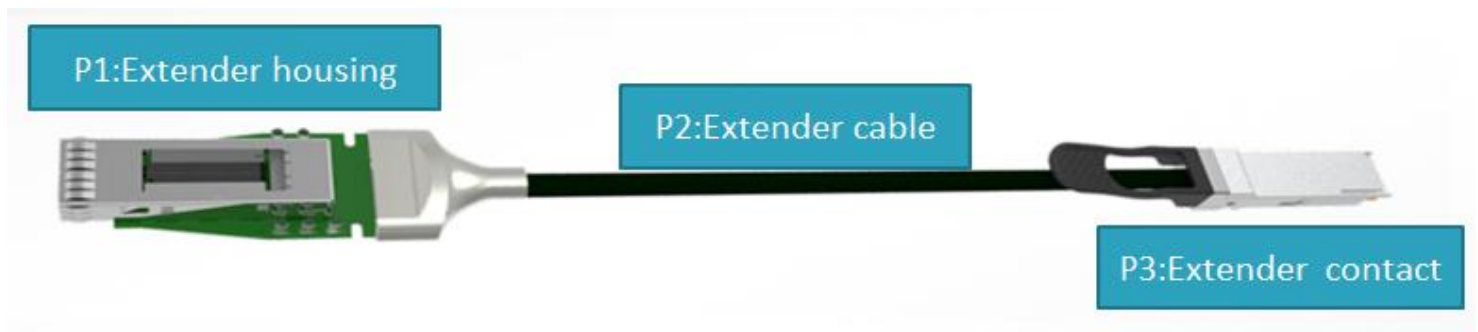

Figure 3 QSFP56 extender main part assembly

Extender contact Pin Description

Pin	Logic	Symbol	Name/Description
1		GND	Module Ground ^{Note5}
2	CML-I	Tx2-	Transmitter inverted data input
3	CML-I	Tx2+	Transmitter non-inverted data input
4		GND	Module Ground ^{Note5}
5	CML-I	Tx4-	Transmitter inverted data input

6	CML-I	Tx4+	Transmitter non-inverted data input
7		GND	Module Ground ^{Note5}
8	LVTTL-I	MODSEIL	Module Select ^{Note6}
9	LVTTL-I	ResetL	Module Reset ^{Note6}
10		VCCR _x	+3.3V Power Supply
11	LVC MOS-I	SCL	2-wire Serial interface clock ^{Note6}
12	LVC MOS-I/O	SDA	2-wire Serial interface data ^{Note6}
13		GND	Module Ground ^{Note5}
14	CML-O	RX3+	Receiver non-inverted data output
15	CML-O	RX3-	Receiver inverted data output
16		GND	Module Ground ^{Note5}
17	CML-O	RX1+	Receiver non-inverted data output
18	CML-O	RX1-	Receiver inverted data output
19		GND	Module Ground ^{Note5}
20		GND	Module Ground ^{Note5}
21	CML-O	RX2-	Receiver inverted data output
22	CML-O	RX2+	Receiver non-inverted data output
23		GND	Module Ground ^{Note5}
24	CML-O	RX4-	Receiver inverted data output
25	CML-O	RX4+	Receiver non-inverted data output
26		GND	Module Ground ^{Note5}
27	LVTTL-O	ModPrsL	Module Present, internal pulled down to GND
28	LVTTL-O	IntL	Interrupt output, should be pulled up on host board ²
29		VCCT _x	+3.3V Transmitter Power Supply
30		VCC1	+3.3V Power Supply
31	LVTTL-I	LPM _{Mode}	Low Power Mode ^{Note6}
32		GND	Module Ground ^{Note5}
33	CML-I	Tx3+	Transmitter non-inverted data input
34	CML-I	Tx3-	Transmitter inverted data input
35		GND	Module Ground ^{Note5}
36	CML-I	Tx1+	Transmitter non-inverted data input
37	CML-I	Tx1-	Transmitter inverted data input
38		GND	Module Ground ^{Note5}

Note:

1. Module circuit ground is isolated from module chassis ground within the module.
2. Open collector should be pulled up with 4.7K to 10K ohms on host board to a voltage between 3.15V and 3.6V.

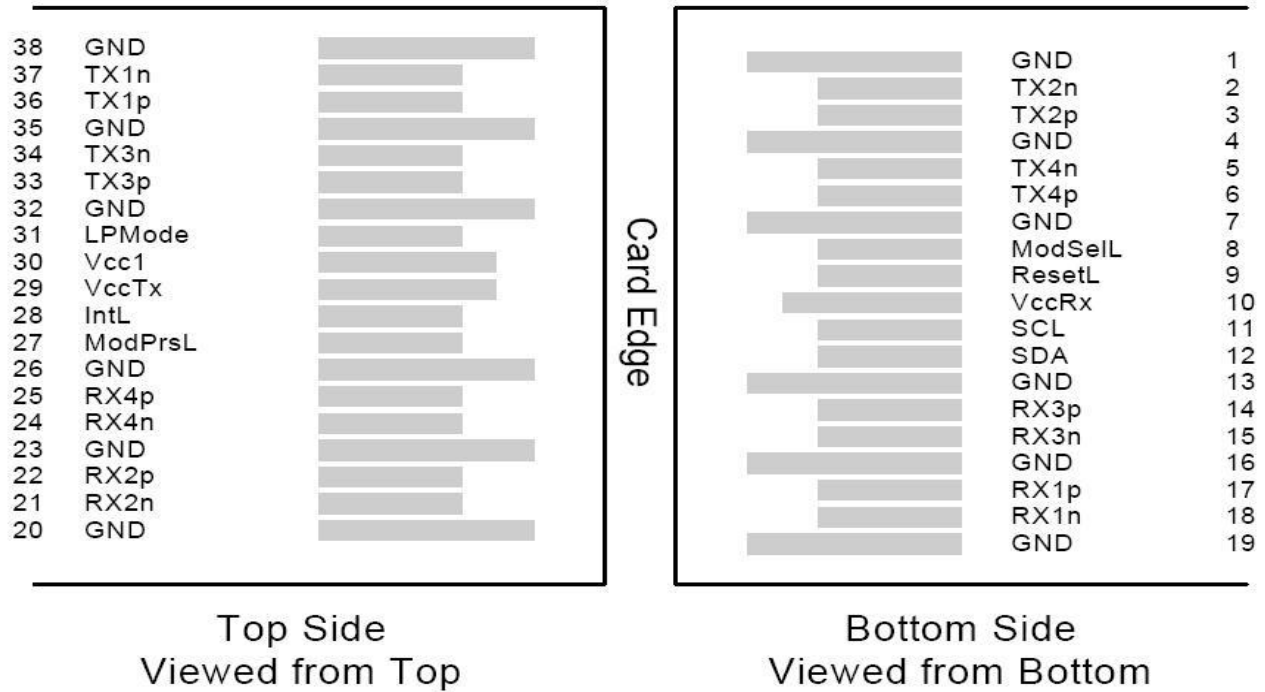

Figure 4. Extender housing QSFP SMT connector pin

Mechanical Dimensions

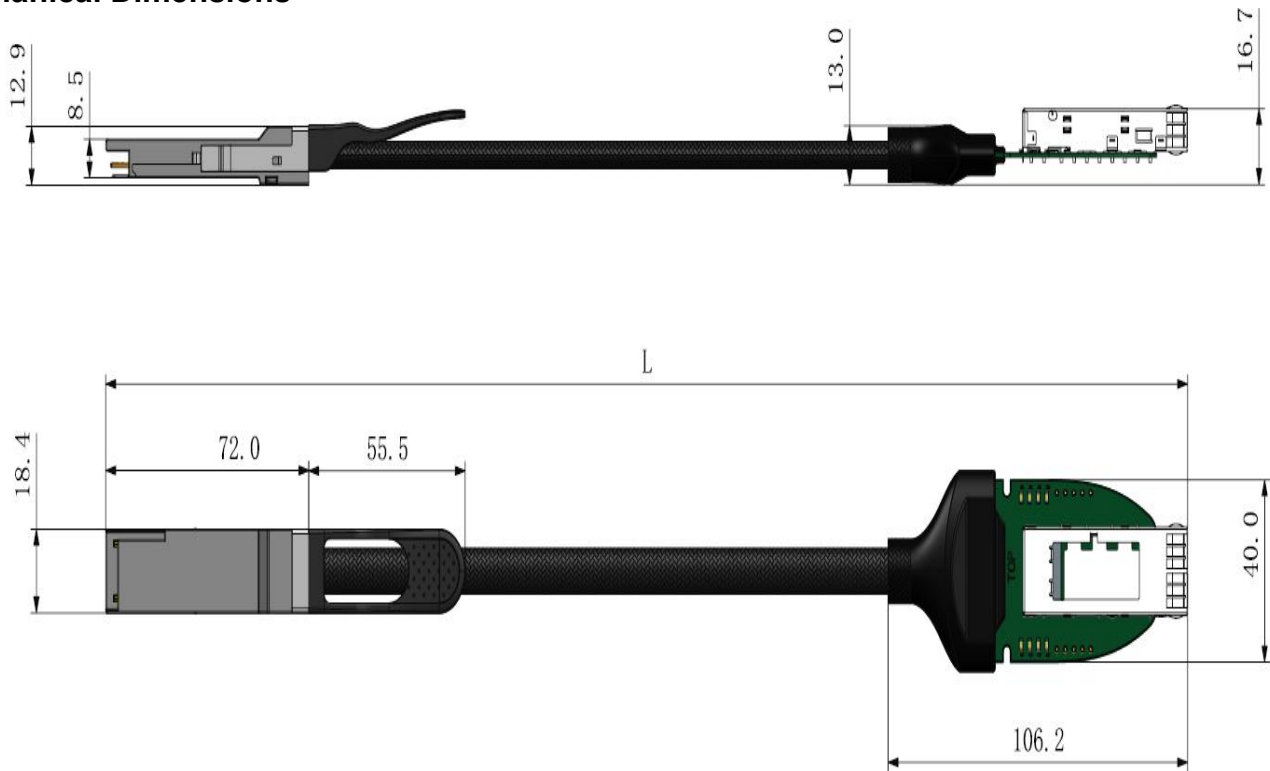

Figure 5. Mechanical Specifications

Wiring Patterns and connection diagram

WIRING TABLE					
P1(Extender contact)			P1(Extender housing)		
01	GND	↔	01	GND	
02	TX2n	↔	02	TX2n	
03	TX2p	↔	03	TX2p	
04	GND	↔	04	GND	
05	TX4n	↔	05	TX4n	
06	TX4p	↔	06	TX4p	
07	GND	↔	07	GND	
08	ModseIL	↔	08	ModseIL	4# LED
09	ResetL	↔	09	ResetL	5# LED
11	SCL	↔	11	SCL	
12	SDA	↔	12	SDA	
13	GND	↔	13	GND	
14	RX3p	↔	14	RX3p	
15	RX3n	↔	15	RX3n	
16	GND	↔	16	GND	
17	RX1p	↔	17	RX1p	
18	RX1n	↔	18	RX1n	
19	GND	↔	19	GND	
20	GND	↔	20	GND	
21	RX2n	↔	21	RX2n	
22	RX2p	↔	22	RX2p	
23	GND	↔	23	GND	
24	RX2n	↔	24	RX2n	
25	RX2p	↔	25	RX2p	
26	GND	↔	26	GND	
27	ModPrsL	↔	27	ModPrsL	3# LED
28	IntL	↔	28	IntL	4# LED
29	VccTx	↔	29	VccTx	1# 2# LED
30	Vcc1		30	Vcc1	
10	VccRx		10	VccRx	
31	LPMode	↔	31	LPMode	8# LED
32	GND	↔	32	GND	
33	TX3p	↔	33	TX3p	
34	TX3n	↔	34	TX3n	
35	GND	↔	35	GND	
36	TX1p	↔	36	TX1p	
37	TX1n	↔	37	TX1n	
38	GND	↔	38	GND	

Figure 6. Wiring Patterns

Extender housing pin and parts

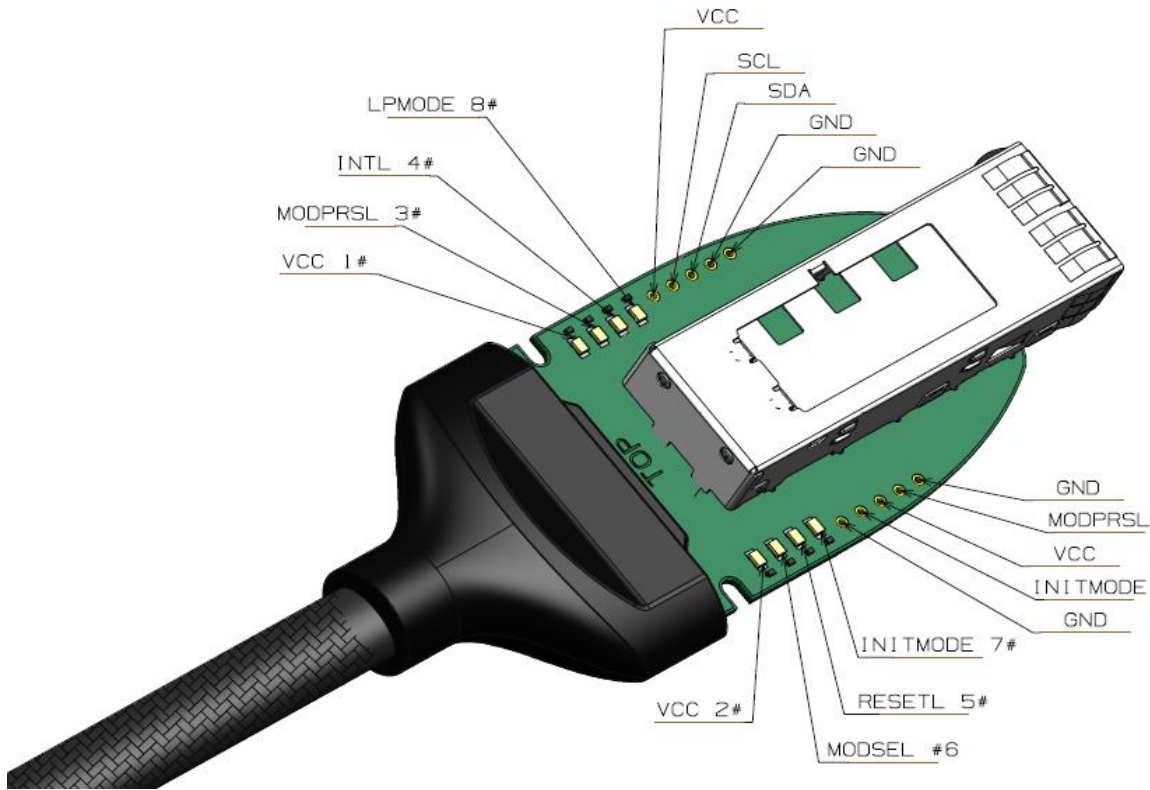

Figure 7. Extender housing pin and parts

Regulatory Compliance

Gigalight's 200GbE immersion cooling extender meet the requirements of the following standards:

Feature	Standard
Electrical Safety	EN 62368-1: 2014 IEC 62368-1:2014 UL 62368-1:2014
Environmental protection	Directive 2011/65/EU with amendment(EU)2015/863
CE EMC	EN55032: 2015 EN55035: 2017 EN61000-3-2:2014 EN61000-3-3:2013
FCC	FCC Part 15, Subpart B; ANSI C63.4-2014

Ordering information

Part Number	Length	Description
GLQE-PC201-D01	10cm	200G QSFP56 extender with high speed cable, with nylon jacket , 0.1meter length with connector and cage.
GLQE-PC201-D05	50cm	200G QSFP56 extender with high speed cable, with nylon jacket , 0.5meter length with connector and cage.

The length(meter) of GLQE-PC201-DXX is decimal and can be customizable.

Important Notice

Performance figures, data and any illustrative material provided in this data sheet are typical and must be specifically confirmed in writing by GIGALIGHT before they become applicable to any particular order or contract. In accordance with the GIGALIGHT policy of continuous improvement specifications may change without notice.

The publication of information in this data sheet does not imply freedom from patent or other protective rights of GIGALIGHT or others. Further details are available from any GIGALIGHT sales representative.

sales@gigalight.com.cn

<http://www.gigalight.com>

Revision History

Revision	Date	Description
V0	Apr-22-2023	Advance Release.