

## 3Gbps Video SFP Optical Receiver With Digital Diagnostic Monitoring GRR-3G-xxxD

### Features

- ◆ HD-SDI SFP Receiver available
- ◆ SD-SDI SFP Receiver available
- ◆ 3G-SDI SFP Receiver available
- ◆ SMPTE 297-2006 Compatible.
- ◆ Metal enclosure for Lower EMI
- ◆ PIN photodetector
- ◆ Supports video pathological patterns for SD-SDI, HD-SDI and 3G-SDI
- ◆ Digital Diagnostic functions available through the I<sup>2</sup>C interface
- ◆ Compatible with RoHS
- ◆ +3.3V single power supply
- ◆ Operating case temperature:  
Standard : 0 to +70°C

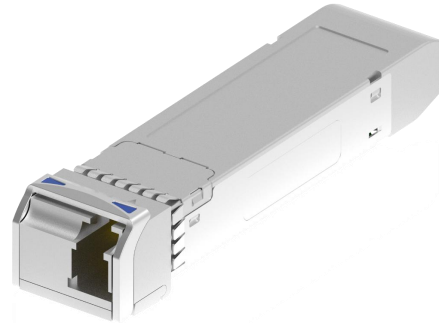

### Applications

- ◆ SMPTE 297-2006 Compatible Electrical-to-Optical Interfaces.
- ◆ HDTV/SDTV Service Interfaces.

### Description

The video series transceivers are high performance, cost effective modules for duplex video transmission application over single mode fiber.

The receiver is designed to receive data rates from 50Mbps to 2.97Gbps and is specifically designed for robust performance in the presence of SDI pathological patterns for SMPTE 259M, SMPTE 344M, SMPTE 292M and SMPTE 424M serial rates. The module is fully compliant with SMPTE 297M-2006.

The receiver is consists of two sections: a PIN photodiode integrated with a trans-impedance preamplifier (TIA) and MCU control unit. All modules satisfy class I laser safety requirements.

### Absolute Maximum Ratings

Parameter	Symbol	Min	Max	Unit
Supply Voltage	Vcc	-0.5	4.5	V
Storage Temperature	Ts	-40	+85	°C
Operating Humidity	-	5	85	%

### Recommended Operating Conditions

Parameter	Symbol	Min	Typical	Max	Unit
Operating Case Temperature	Standard	0		+70	°C
					°C
Power Supply Voltage	Vcc	3.13	3.3	3.47	V
Power Supply Current	Icc			150	mA
Data Rate			3		Gbps

### Optical and Electrical Characteristics

Parameter	Symbol	Min	Typical	Max	Unit	Notes
Receiver						
Rise/Fall Time (20%~80%)	SD-SDI	tr/TF		1500	ps	1
	HD-SDI			270		
	3G-SDI			135		
Total Output Jitter	PRBS and colour bar	SD-SDI	70	200	ps	
		HD-SDI	50	135		
		3G-SDI	70	100		
	pathological	SD-SDI	200	300		
		HD-SDI	115			
		3G-SDI	120			
Centre Wavelength	$\lambda_c$	1260		1580	nm	

Receiver Sensitivity (PRBS)	SD-SDI			-20	dBm	
	HD-SDI			-20	dBm	
	3G-SDI			-20	dBm	
Receiver Sensitivity (Pathological)	SD-SDI			-16	dBm	
	HD-SDI			-15	dBm	
	3G-SDI			-14	dBm	
Receiver Overload		0			dBm	3
LOS De-Assert	LOS <sub>D</sub>			-20	dBm	
LOS Assert	LOS <sub>A</sub>	-30			dBm	
LOS Hysteresis		1		4	dB	
Data Output Swing Differential	Vout	650	800	1000	mV	2
LOS	High	2.0		Vcc	V	
	Low			0.8	V	

**Notes:**

1. Rise and fall times, 20% to 80%, are measured following a fourth-order Bessel-Thompson filter with a bandwidth of 0.75 x clock frequency corresponding to the serial data rate
2. PECL input, internally AC-coupled and terminated.
3. Internally AC-coupled.

**Timing and Electrical**

Parameter	Symbol	Min	Typical	Max	Unit
LOS Assert Time	t_loss_on			100	μs
LOS De-assert Time	t_loss_off			100	μs
Serial ID Clock Rate	f_serial_clock			280	KHz
MOD_DEF (0:2)-High	V <sub>H</sub>	2		Vcc	V
MOD_DEF (0:2)-Low	V <sub>L</sub>			0.8	V

**Diagnostics**

Parameter	Range	Unit	Accuracy	Calibration
-----------	-------	------	----------	-------------

Temperature	0 to +70	°C	±3°C	Internal / External
Voltage	3.0 to 3.6	V	±3%	Internal / External
RX Power	-20 to -6	dBm	±3dB	Internal / External

## I2C Bus Interface

The I2C bus interface uses the 2-wire serial CMOS E2PROM protocol. The serial interface meets the following specifications:

1. Support a maximum clock rate of 280Khz.
2. Input/Output levels comply with LVCMOS/LVTTL or compatible logics.

Low: 0 – 0.8 V

High: 2.0 – 3.3 V

Undefined: 0.8 – 2.0 V

## Pin Definitions(Non-MSA)

### Pin Diagram

Top of Board

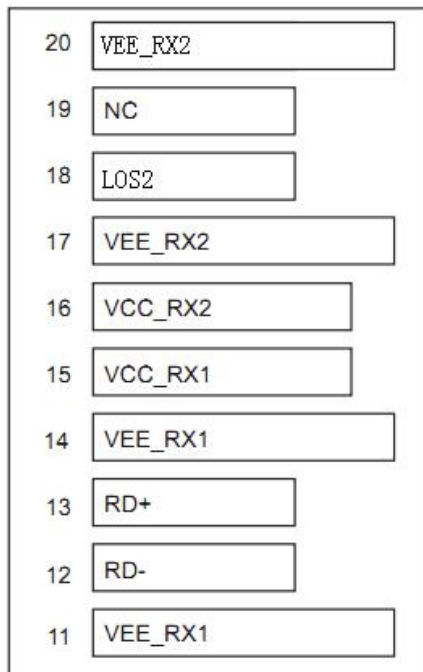

Bottom of Board

(as viewed through top of board)

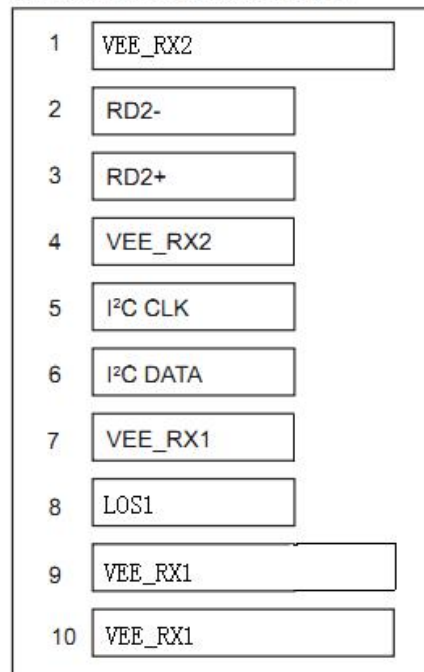

## Pin Descriptions

Pin	Signal Name	Description	Plug Seq.	Notes
-----	-------------	-------------	-----------	-------

1	VEE_RX2	Receiver2 Ground	1	
2	RD2-	Inv. Received2 Data Out	3	Note 1
3	RD2+	Received2 Data Out	3	
4	VEE_RX2	Receiver2 Ground	3	
5	I2C CLK	SCL Serial Clock Signal	3	Note 3
6	I2C DATA	SDA Serial Data Signal	3	Note 3
7	VEE_RX1	Receiver1 Ground	3	
8	LOS1	Loss1 of Signal	3	Note 4
9	VEE_RX1	Receiver1 Ground	1	Note 4
10	VEE_RX1	Receiver1 ground	1	Note 2
11	VEE_RX1	Receiver1 ground	1	
12	RD-	Inv. Received Data Out	3	Note 1
13	RD+	Received Data Out	3	
14	VEE_RX1	Receiver1 ground	1	
15	VCC_RX1	Receiver1 Power Supply	2	
16	VCC_RX2	Receiver2 Power Supply	2	
17	VEE_RX2	Receiver2 Ground	1	
18	LOS2	Loss2 of Signal	3	Note 4
19	NC	Not Connected	3	Note 4
20	VEE_RX2	Receiver2 Ground	1	Note 2

**Notes:**

Plug Seq.: Pin engagement sequence during hot plugging.

- 1) These are the module definition pins. They should be pulled up with a 4.7k~10kΩ resistor on the host board. The pull-up voltage shall be VccR.  
I2C CLK is the clock line of two wire serial interface for serial ID  
I2C DATA is the data line of two wire serial interface for serial ID
- 2) LOS is an open collector output, which should be pulled up with a 4.7k~10kΩ resistor. Pull up voltage between 2.0V and Vcc+0.3V. Logic 1 indicates loss of signal; Logic 0 indicates normal operation. In the low state, the output will be pulled to less than 0.8V.
- 3) RD-/+ : These are the differential receiver outputs. They are internally AC-coupled 100 differential lines which should be terminated with 100Ω (differential) at the user SERDES.

## Mechanical Dimensions

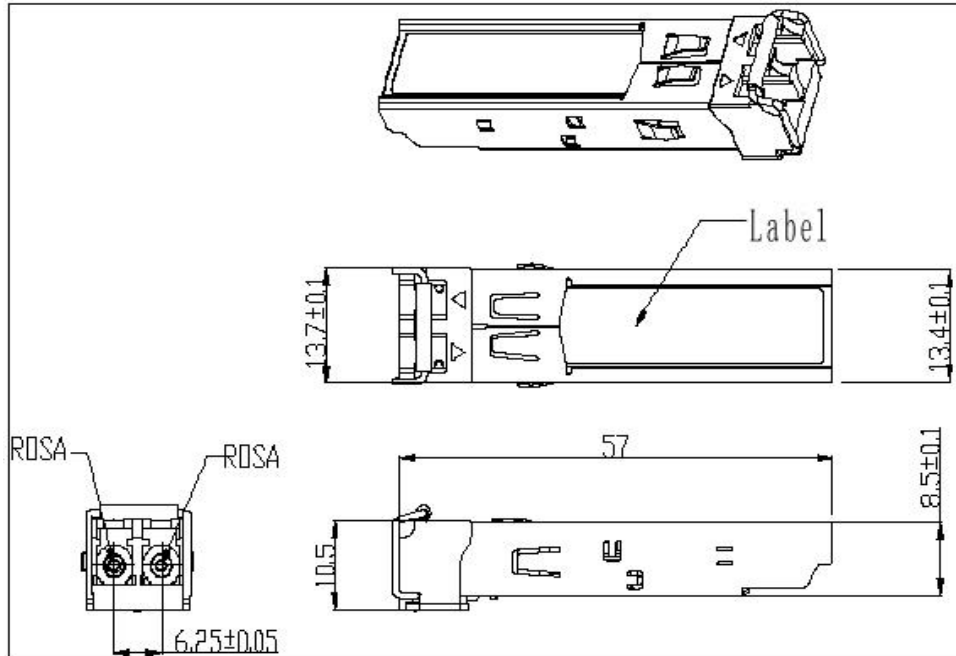

## Ordering information

Part Number	Product Description
GRR-3G-XXCD	PIN, 3Gbps, 0°C ~ +70°C, With Digital Diagnostic Monitoring, non-msa Pinoout

## Important Notice

Performance figures, data and any illustrative material provided in this data sheet are typical and must be specifically confirmed in writing by GIGALIGHT before they become applicable to any particular order or contract. In accordance with the GIGALIGHT policy of continuous improvement specifications may change without notice.

The publication of information in this data sheet does not imply freedom from patent or other protective rights of GIGALIGHT or others. Further details are available from any GIGALIGHT sales representative.

Email: [sales@gigalight.com.cn](mailto:sales@gigalight.com.cn)

<http://www.gigalight.com.cn>

## Revision History

Version	Date	Description
V0	Mar. 10th, 2012	New release
V1	Oct. 20th, 2021	Change Max PRBS receiver sensitivity -22dBm to -20dBm; Change Max pathological Rx sensitivity SD-SDI -20dBm to -16dBm, HD-SDI -22 to -15dBm, 3G-SDI -22 to -14dBm