

GHR-3G-xxxD

3G-SDI SFP Rx, with DDM (V1)

Features

- ◆ HD-SDI SFP Receiver available
- ◆ SD-SDI SFP Receiver available
- ◆ 3G-SDI SFP Receiver available
- ◆ SMPTE 297-2006 Compatible.
- ◆ Metal enclosure for Lower EMI
- ◆ PIN photodetector
- ◆ Supports video pathological patterns for SD-SDI, HD-SDI and 3G-SDI
- ◆ SFP Non-MSA Pinout
- ◆ Digital Diagnostic functions available through the I²C interface
- ◆ Compatible with RoHS
- ◆ +3.3V single power supply
- ◆ Operating case temperature:
Standard : 0 to +70°C

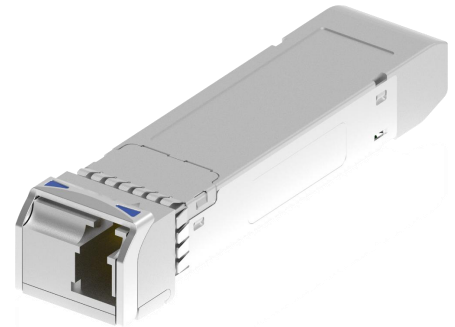

Applications

- ◆ SMPTE 297-2006 Compatible Electrical-to-Optical Interfaces.
- ◆ HDTV/SDTV Service Interfaces.

Description

The video series transceivers are high performance, cost effective modules for duplex video transmission application over single mode fiber.

The receiver is designed to receive data rates from 50Mbps to 2.97Gbps and is specifically designed for robust performance in the presence of SDI pathological patterns for SMPTE 259M, SMPTE 344M, SMPTE 292M and SMPTE 424M serial rates. The module is fully compliant with SMPTE 297M-2006.

The receiver is consists of a PIN photodiode integrated with a trans-impedance preamplifier (TIA) and MCU control unit. All modules satisfy class I laser safety requirements.

The receivers are compatible with SFP Multi-Source Agreement (MSA) and SFF-8472. For further information, please refer to SFP MSA.

Absolute Maximum Ratings

Parameter	Symbol	Min	Max	Unit
Supply Voltage	Vcc	-0.5	4.5	V
Storage Temperature	Ts	-40	+85	°C
Operating Humidity	-	5	85	%

Recommended Operating Conditions

Parameter	Symbol	Min	Typical	Max	Unit
Operating Case Temperature	Standard	0		+70	°C
	I				°C
Power Supply Voltage	Vcc	3.13	3.3	3.47	V
Power Supply Current	Icc			150	mA
Data Rate			3		Gbps

Optical and Electrical Characteristics

Parameter	Symbol	Min	Typical	Max	Unit	Notes	
Receiver							
Rise/Fall Time (20%~80%)	SD-SDI	tr/ff			1500	ps	1
	HD-SDI				270		
	3G-SDI				135		
Total Output Jitter	PRBS and colour bar	SD-SDI		70	200	ps	
		HD-SDI		50	135		
		3G-SDI		70	100		
	pathological	SD-SDI		200	300		
		HD-SDI		115			
		3G-SDI		120			
Centre Wavelength	λ_c	1260		1580	nm		
Receiver Sensitivity (PRBS)	SD-SDI			-20	dBm		
	HD-SDI			-20	dBm		

	3G-SDI				-20	dBm	
Receiver Sensitivity (Pathological)	SD-SDI				-16	dBm	
	HD-SDI				-15	dBm	
	3G-SDI				-14	dBm	
	Receiver Overload		0			dBm	3
LOS De-Assert	LOS _D				-20	dBm	
LOS Assert	LOS _A	-30				dBm	
LOS Hysteresis		1			4	dB	
Data Output Swing Differential	V _{out}	650	800	1000		mV	2
LOS	High	2.0			V _{cc}	V	
	Low				0.8	V	

Notes:

1. Rise and fall times, 20% to 80%, are measured following a fourth-order Bessel-Thompson filter with a bandwidth of 0.75 x clock frequency corresponding to the serial data rate
2. PECL input, internally AC-coupled and terminated.
3. Internally AC-coupled.

Timing and Electrical

Parameter	Symbol	Min	Typical	Max	Unit
LOS Assert Time	t _{loss_on}			100	μs
LOS De-assert Time	t _{loss_off}			100	μs
Serial ID Clock Rate	f _{serial_clock}			280	KHz
MOD_DEF (0:2)-High	V _H	2		V _{cc}	V
MOD_DEF (0:2)-Low	V _L			0.8	V

Diagnostics Specification

Parameter	Range	Unit	Accuracy	Calibration
Temperature	0 to +70	°C	±3°C	Internal / External

Voltage	3.0 to 3.6	V	±3%	Internal / External
RX Power	-20 to -6	dBm	±3dB	Internal / External

I2C Bus Interface

The I2C bus interface uses the 2-wire serial CMOS E2PROM protocol. The serial interface meets the following specifications:

- 1.Support a maximum clock rate of 280Khz.
2. Input/Output levels comply with LVCMOS/LVTTL or compatible logics.

Low: 0 – 0.8 V

High: 2.0 – 3.3 V

Undefined: 0.8 – 2.0 V

Pin Definitions (Non-MSA)

Pin Diagram

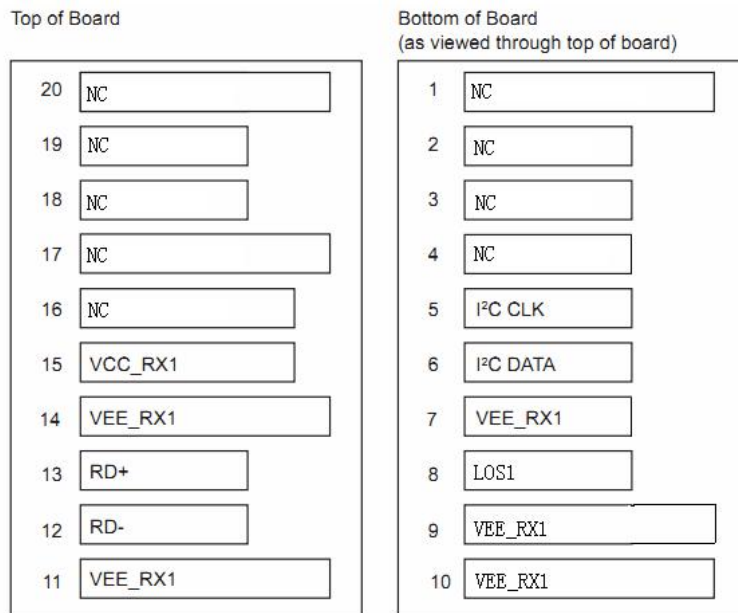

Pin Descriptions

Pin	Signal Name	Description	Plug Seq.	Notes
1	NC	Not Connected	1	
2	NC	Not Connected	3	

3	NC	Not Connected	3	
4	NC	Not Connected	3	
5	I2C CLK	SCL Serial Clock Signal	3	Note 1
6	I2C DATA	SDA Serial Data Signal	3	Note 1
7	VEE_RX1	Receiver1 Ground	3	
8	LOS1	Loss of Signal	3	Note 2
9	VEE_RX1	Receiver1 Ground	1	
10	VEE_RX1	Receiver1 ground	1	
11	VEE_RX1	Receiver1 ground	1	
12	RD-	Inv. Received Data Out	3	Note 3
13	RD+	Received Data Out	3	Note 3
14	VEE_RX1	Receiver1 ground	1	
15	VCC_RX1	Receiver1 Power Supply	2	
16	NC	Not Connected	2	
17	NC	Not Connected	1	
18	NC	Loss of Signal	3	
19	NC	Not Connected	3	
20	NC	Not Connected	1	

Notes:

Plug Seq.: Pin engagement sequence during hot plugging.

- 1) These are the module definition pins. They should be pulled up with a 4.7k~10kΩ resistor on the host board. The pull-up voltage shall be VccR.
I2C CLK is the clock line of two wire serial interface for serial ID
I2C DATA is the data line of two wire serial interface for serial ID
- 2) LOS is an open collector output, which should be pulled up with a 4.7k~10kΩ resistor. Pull up voltage between 2.0V and Vcc+0.3V. Logic 1 indicates loss of signal; Logic 0 indicates normal operation. In the low state, the output will be pulled to less than 0.8V.
- 3) RD-/+: These are the differential receiver outputs. They are internally AC-coupled 100 differential lines which should be terminated with 100Ω (differential) at the user SERDES.

Mechanical Dimensions

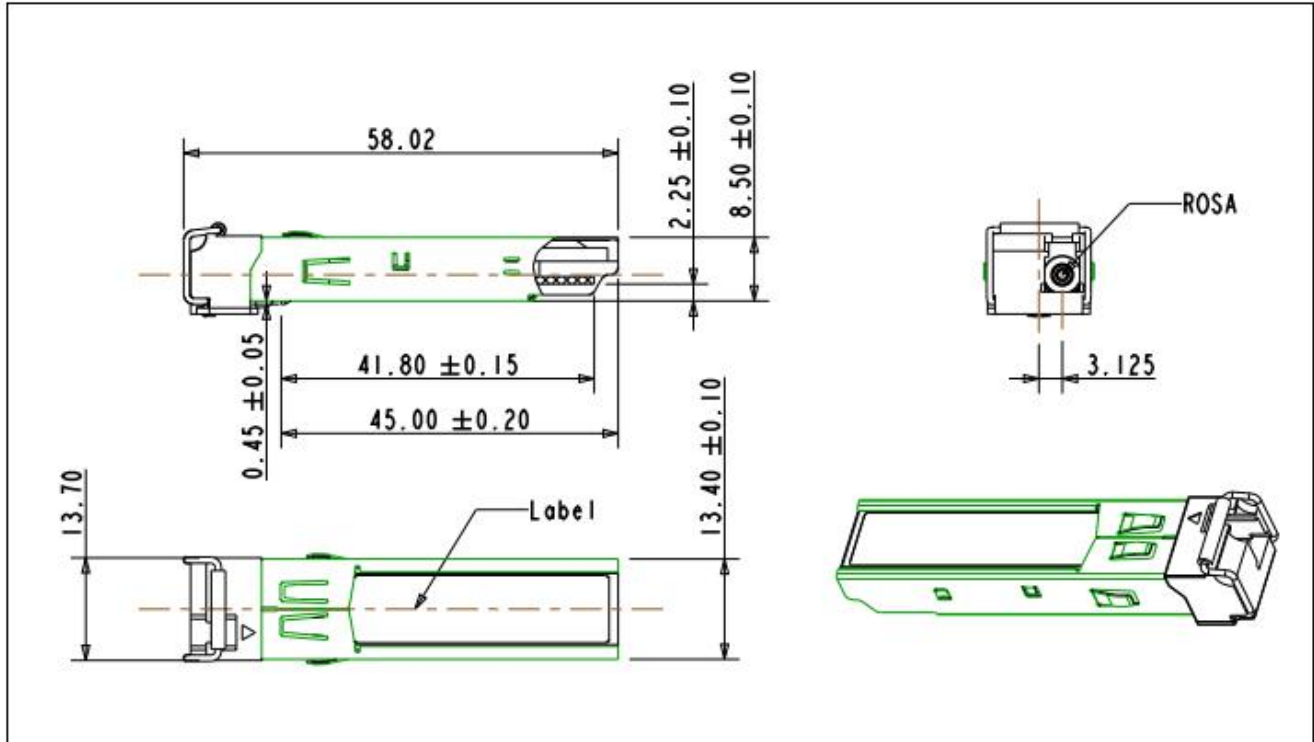

Ordering information

Part Number	Product Description
GHR-3G-XXCD	PIN, 3Gbps, 0°C ~ +70°C, With Digital Diagnostic Monitoring, Non-MSA Pinout

Important Notice

Performance figures, data and any illustrative material provided in this data sheet are typical and must be specifically confirmed in writing by GIGALIGHT before they become applicable to any particular order or contract. In accordance with the GIGALIGHT policy of continuous improvement specifications may change without notice.

The publication of information in this data sheet does not imply freedom from patent or other protective rights of GIGALIGHT or others. Further details are available from any GIGALIGHT sales representative.

E-mail: sales@gigalight.com.cn

Web : <http://www.gigalight.com.cn>



Revision History

Version	Date	Description
V0	Mar. 10th, 2012	New release
V1	Oct. 20th, 2021	Change Max PRBS receiver sensitivity -22dBm to -20dBm; Change Max pathological Rx sensitivity SD-SDI -20dBm to -16dBm, HD-SDI -22dBm to -15dBm, 3G-SDI -22dBm to -14dBm