

GCB-3448-L2C(D)

2.488Gbps Compact Bi-Di SFP Transceiver, 20km Reach

1310nm TX / 1490 nm RX

Features

- ◆ Support 2.488Gbps data links
- ◆ 1310nm DFB laser and PIN photodetector for 20km transmission
- ◆ 2xBi-directional transceivers in 1 SFP transceiver package
- ◆ Compliant with CSFP MSA Option 2 and SFF-8472
- ◆ Digital Diagnostic Monitoring:
Internal Calibration or External Calibration
- ◆ Compatible with SONET OC-48 system
- ◆ Compatible with RoHS
- ◆ +3.3V single power supply
- ◆ Operating case temperature:
0 to +70°C(Commercial)



Applications

- ◆ SDH STM-16 and SONET OC-48 system
- ◆ Fiber Channel
- ◆ Switch to Switch interface
- ◆ Point to Point FTTH Application
- ◆ Other optical transmission systems

Description

The CSFP transceivers are high performance, cost effective modules supporting 2.488Gbps and 20km transmission distance with SMF.

The transceiver consists of three sections: a DFB laser transmitter, a PIN photodiode integrated with a trans-impedance preamplifier (TIA) and MCU control unit. All modules satisfy class I laser safety requirements.

The transceivers are compatible with Compact SFP Multi-Source Agreement (MSA) and SFF-8472. For further information, please refer to SFP MSA.

Block Diagram

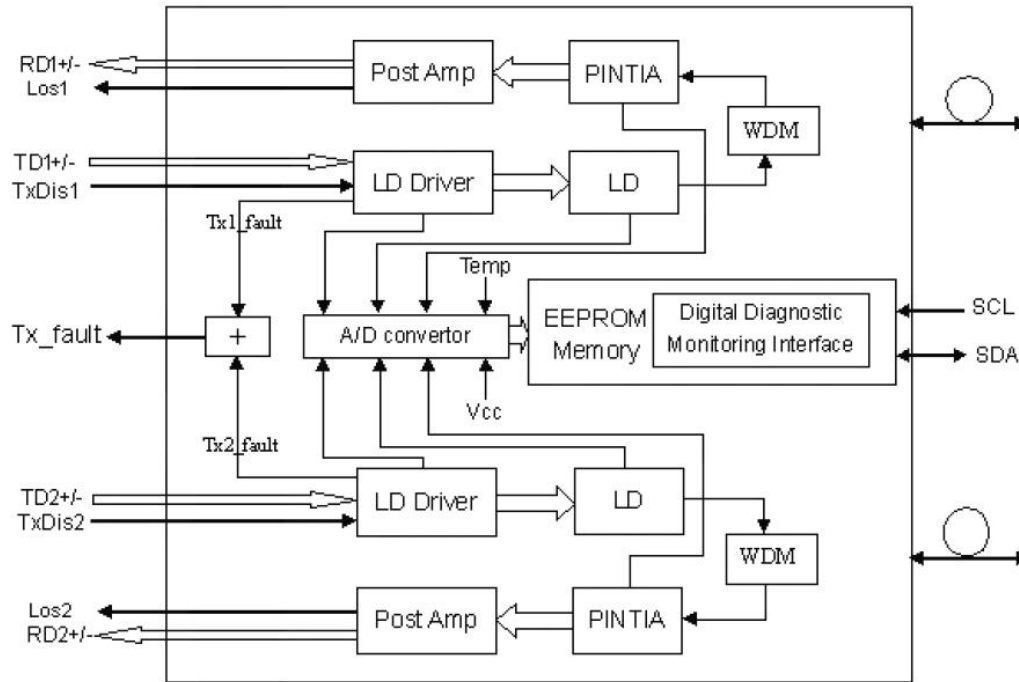

Absolute Maximum Ratings

Table 1 - Absolute Maximum Ratings

Parameter	Symbol	Min	Max	Unit
Supply Voltage	Vcc	-0.5	4.5	V
Storage Temperature	Ts	-40	+85	°C
Operating Humidity	-	5	85	%

Recommended Operating Conditions

Table 2 - Recommended Operating Conditions

Parameter	Symbol	Min	Typical	Max	Unit
Operating Case Temperature	Tc	0		+70	°C
Commercial					
Power Supply Voltage	Vcc	3.13	3.3	3.47	V
Power Supply Current	Icc			550	mA
Data Rate				2488	Mbps

Optical and Electrical Characteristics

GPB-3448x-L2C(D): (DFB and PIN, 1310nm, 20km Reach)

Table 3 - Optical and Electrical Characteristics

Parameter	Symbol	Min	Typical	Max	Unit	Notes
Transmitter						
Centre Wavelength	λ_c	1260	1310	1360	nm	
Spectral Width (-20dB)	σ			1	nm	
Side Mode Suppression Ratio	SMSR	30			dB	
Average Output Power	P _{out}	-5		0	dBm	1
Extinction Ratio	ER	9			dB	
Optical Rise/Fall Time (20%~80%)	tr/tf			0.16	ns	
Data Input Swing Differential	V _{IN}	400		1800	mV	2
Input Differential Impedance	Z _{IN}	90	100	110	Ω	
TX Disable	Disable	2.0		V _{cc}	V	
	Enable	0		0.8	V	
TX Fault	Fault	2.0		V _{cc}	V	
	Normal	0		0.8	V	
Receiver						
Centre Wavelength	λ_c	1470		1510	nm	
Receiver Sensitivity				-19	dBm	3
Receiver Overload		0			dBm	3
LOS De-Assert	LOS _D			-19	dBm	
LOS Assert	LOS _A	-30			dBm	
LOS Hysteresis		1		4	dB	
Data Output Swing Differential	V _{out}	400		1800	mV	4
LOS	High	2.0		V _{cc}	V	
	Low			0.8	V	

Notes:

1. The optical power is launched into SMF.
2. PECL input, internally AC-coupled and terminated.
3. Measured with a PRBS 2²³-1 test pattern @2488Mbps, BER $\leq 1 \times 10^{-12}$.
4. Internally AC-coupled.

Timing and Electrical

Table 4 - Timing and Electrical

Parameter	Symbol	Min	Typical	Max	Unit
Tx Disable Negate Time	t_on			1	ms
Tx Disable Assert Time	t_off			10	µs
Time To Initialize, including Reset of Tx Fault	t_init			300	ms
Tx Fault Assert Time	t_fault			100	µs
Tx Disable To Reset	t_reset	10			µs
LOS Assert Time	t_loss_on			100	µs
LOS De-assert Time	t_loss_off			100	µs
Serial ID Clock Rate	f_serial_clock			400	KHz
MOD_DEF (1,2)-High	V _H	2		V _{cc}	V
MOD_DEF (1,2)-Low	V _L			0.8	V

Diagnostics

Table 5 – Diagnostics Specification

Parameter	Range	Unit	Accuracy	Calibration
Temperature	0 to +70	°C	±3°C	Internal / External
Voltage	3.0 to 3.6	V	±3%	Internal / External
Bias Current	0 to 100	mA	±10%	Internal / External
TX Power	-5 to 0	dBm	±3dB	Internal / External
RX Power	-23 to -3	dBm	±3dB	Internal / External

Digital Diagnostic Memory Map

The transceivers provide serial ID memory contents and diagnostic information about the present operating conditions by the 2-wire serial interface (SCL, SDA).

The diagnostic information with internal calibration or external calibration all are implemented, including received power monitoring, transmitted power monitoring, bias current monitoring, supply voltage monitoring and temperature monitoring.

The digital diagnostic memory map specific data field defines as following.

- A0h/A2h for Channel1
- B0h/B2h for Channel2

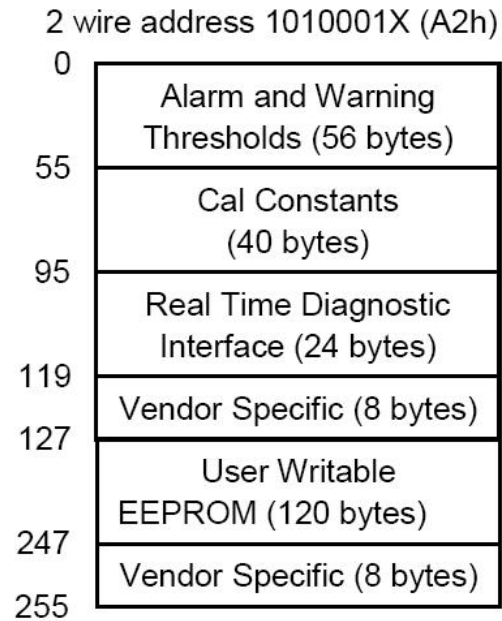
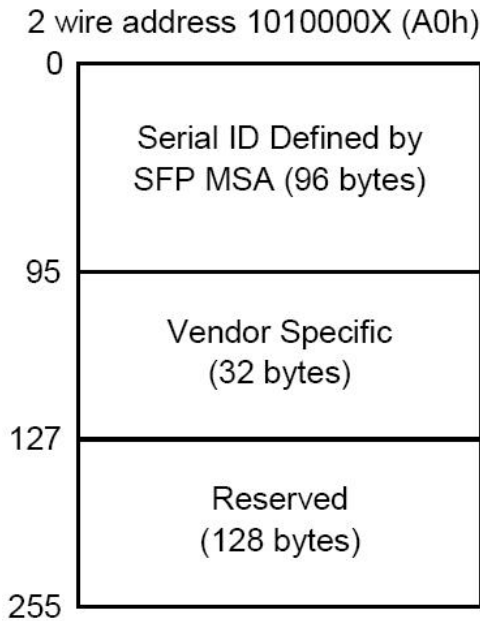

Channel 1

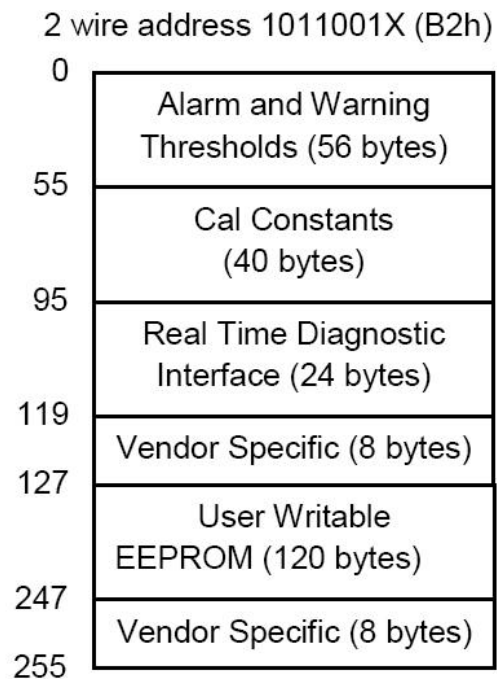
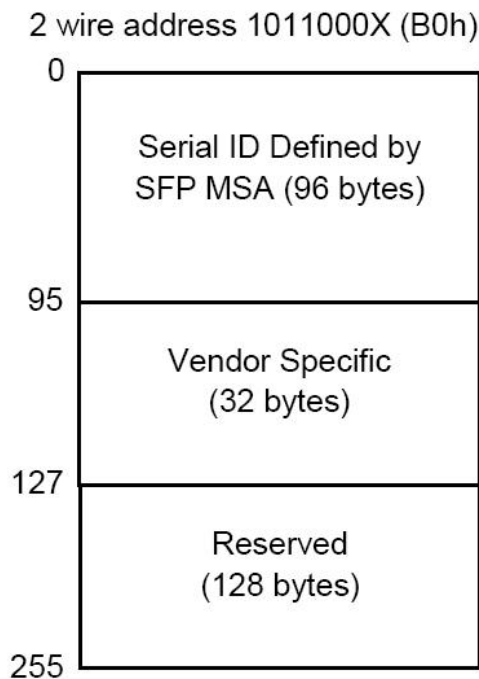

Channel 2

Pin Definitions

CSFP MSA option 2

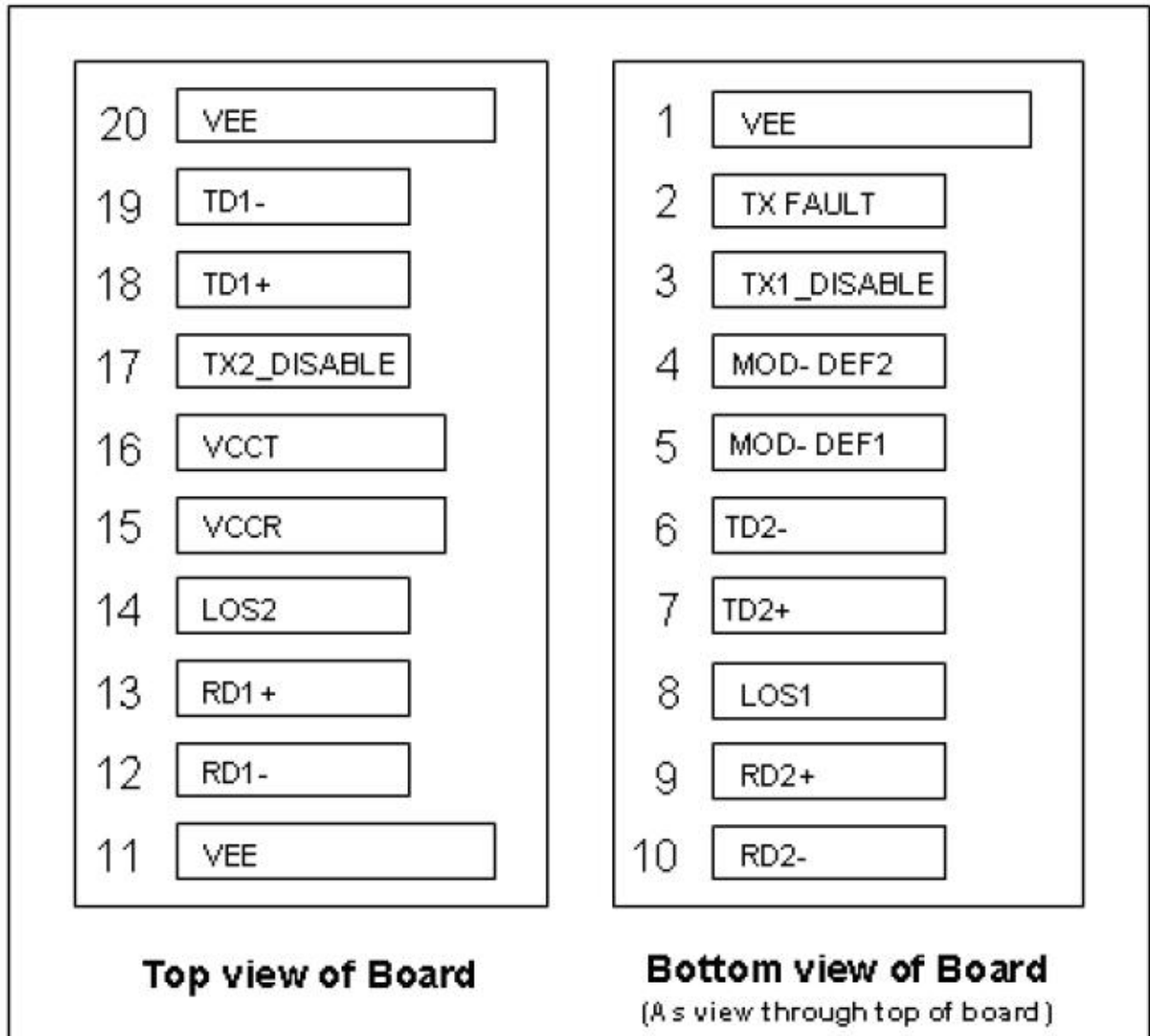

Pin Descriptions

Pin	Name	Description	Plug Seq	Notes
1	VEE	Transceiver ground, common for 2 channels		
2	Tx_ Fault	Open collector/drain output, high signal indicates fault in one of the TX channels		
3	TX_DI S1	Transmitter disable control of channel 1, high signal disables optical output		
4	SDA	I2C data (SDA)		
5	SCL	I2C clock (SCL)		
6	TD-2	Inverted transmitter data input of channel 2 (internally AC coupled)		
7	TD+2	Non-inverted transmitter data input of channel 2 (internally AC coupled)		
8	LOS1	Open collector/drain output, high signal indicates los of signal in RX channel 1		
9	RD+2	Non-inverted receiver data output of channel 2 (internally AC coupled)		
10	RD-2	Inverted receiver data output of channel 2 (internally AC coupled)		
11	VEE	Transceiver ground, common for 2 channels		
12	RD-1	Inverted receiver data output of channel 1 (internally AC coupled)		
13	RD+1	Non-inverted receiver data output of channel 1 (internally AC coupled)		
14	LOS2	Open collector/drain output, high signal indicates los of signal in RX channel 2		
15	VccR	Receiver power, common for 2 channels		
16	VccT	Transmitter power, common for 2 channels		
17	TX_ DIS2	Transmitter disable control of channel 2, high signal disables optical output		
18	TD+1	Non-inverted transmitter data input of channel 1 (internally AC coupled)		
19	TD-1	Inverted transmitter data input of channel 1 (internally AC coupled)		
20	VEE	Transceiver ground, common for 2 channels		

Notes:

Plug Seq.: Pin engagement sequence during hot plugging.

1) TX Fault report transceiver status as following:

TX Fault is an open collector/drain output, which should be pulled up with a 4.7K–10kΩ resistor on the host board. Pull up voltage between 2.0V and VccT, R+0.3V. When high, output indicates a laser fault of some kind either in Channel 1 or Channel 2. The Host shall read Channel 1/2:A2H/AAH: 110 for details: TX Fault from channel 1 if bit 2 is set in [A2H:110]; TX Fault from channel 2 if bit 2 is set in [B2H: 110]. Low indicates normal operation. In the low state, the output will be pulled to < 0.8V.

2) TX_disable1, 2 are an input that is used to shut down the transmitter optical output. It is pulled up within the module with a 4.7–10 kΩ resistor. Its states are:

Low (0 – 0.8V): Transmitter on
(>0.8V, < 2.0V): Undefined
High (2.0 to 3.465V): Transmitter Disabled
Open: Transmitter Disabled

3) Mod-Def 1,2. These are the module definition pins. They should be pulled up with a 4.7k~10kΩ resistor on the host board. The pull-up voltage shall be VccT or VccR.

Mod-Def 1 is the clock line of two wire serial interface for serial ID

Mod-Def 2 is the data line of two wire serial interface for serial ID

4) LOS 1,2 is an open collector output, which should be pulled up with a 4.7k~10kΩ resistor. Pull up voltage between 2.0V and Vcc+0.3V. Logic 1 indicates loss of signal; Logic 0 indicates normal operation. In the low state, the output will be pulled to less than 0.8V.

5) RD1,2-/+ : These are the differential receiver outputs. They are internally AC-coupled 100 differential lines which should be terminated with 100Ω (differential) at the user SERDES.

6) TD1,2-/+ : These are the differential transmitter inputs. They are internally AC-coupled, differential lines with 100Ω differential termination inside the module.

Recommended Interface Circuit

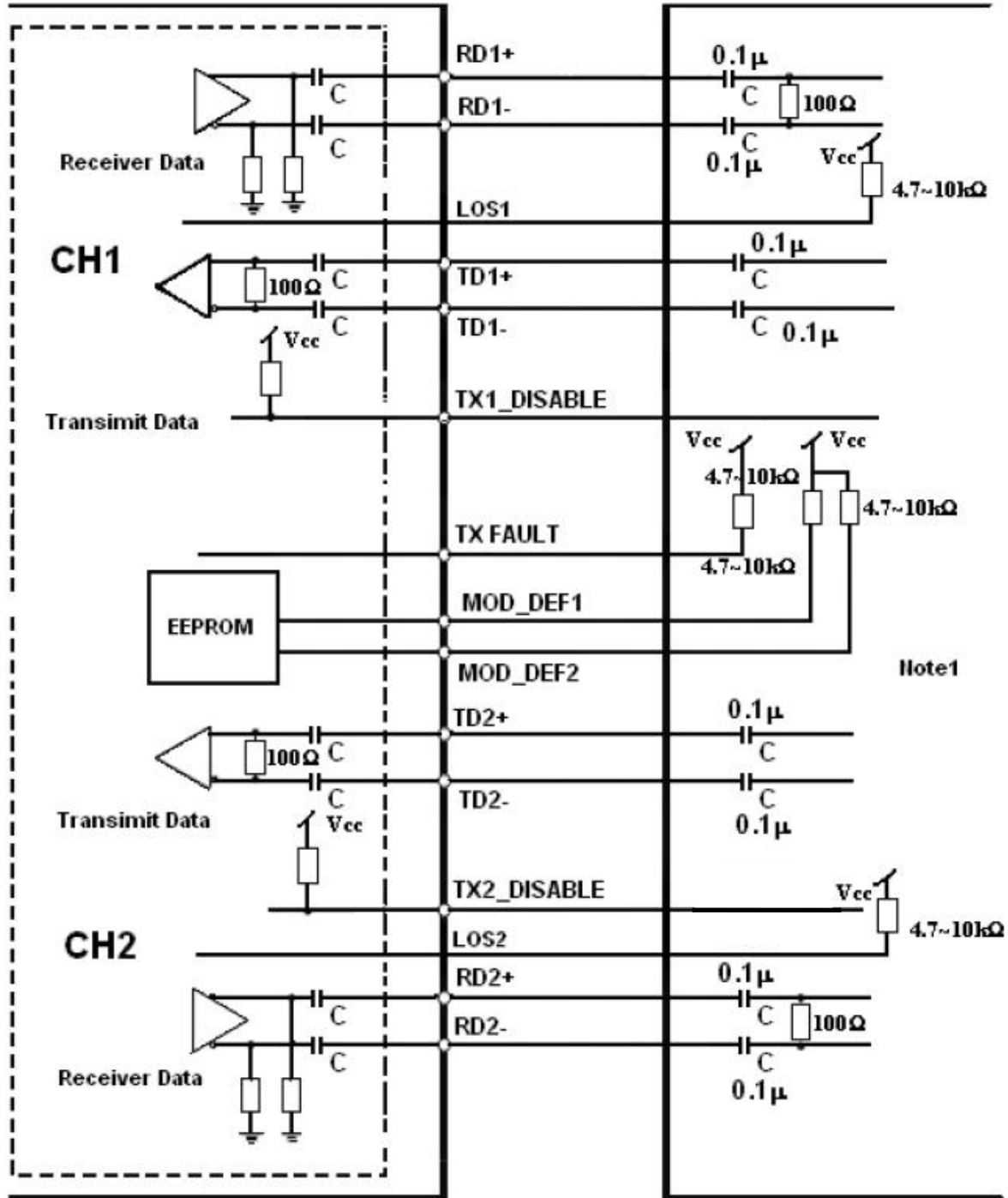

Mechanical Dimensions

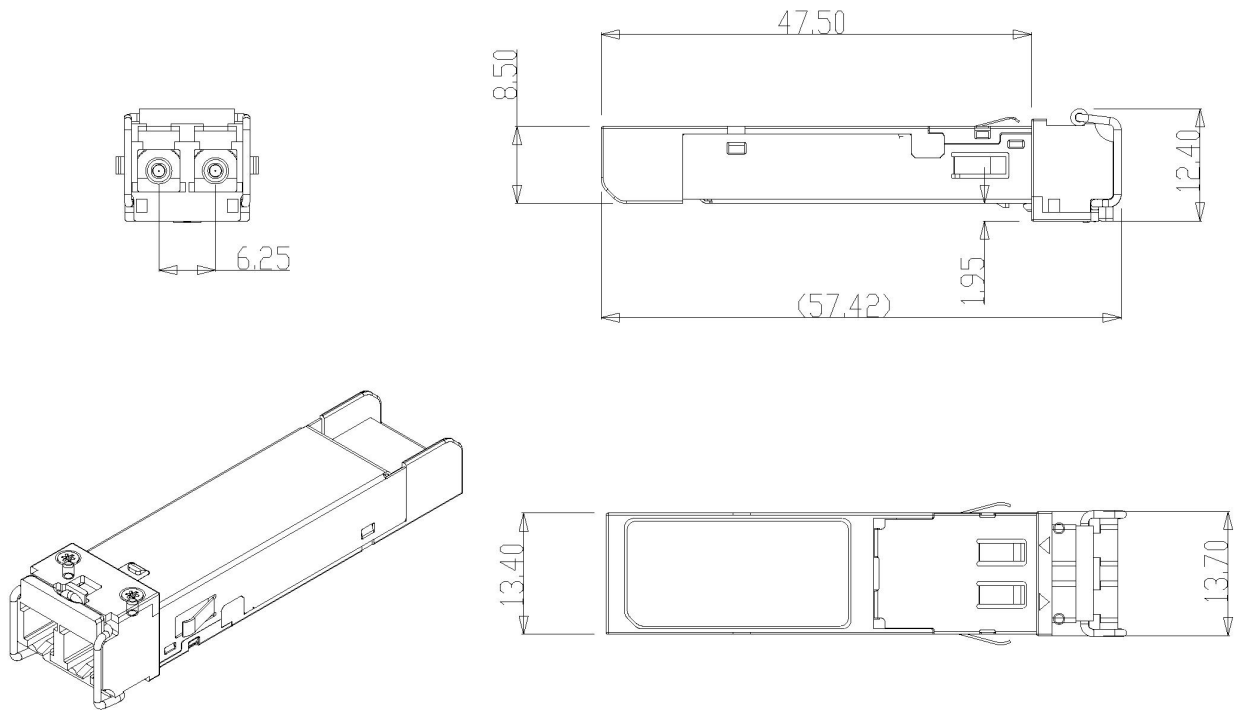

Ordering information

Part Number	Product Description
GCB-3448-L2C(D)	2.5Gbps, Tx1310nm / Rx 1490nm; Compact SFP bidi, 20KM, DDM 0°C ~ +70°C

Email: sales@gigalight.com.cn

<http://www.gigalight.com.cn>