

## GPH-3102-L1C(D) 100BASE-LX Spring-Latch SFP Transceiver, 10km Reach

### Features

- ◆ Build-in PHY supporting SGMII Interface
- ◆ 100BASE-LX operation
- ◆ 1310nm FP laser and PIN photo-detector
- ◆ 10km transmission with SMF
- ◆ Standard serial ID information Compatible with SFP MSA
- ◆ SFP MSA package with duplex LC connector
- ◆ With Spring-Latch for high density application
- ◆ Very low EMI and excellent ESD protection
- ◆ +3.3V single power supply
- ◆ Operating case temperature: 0 to +70°C



### Applications

- ◆ Switch to Switch interface
- ◆ Switched backplane applications
- ◆ Router/Server interface
- ◆ Other optical transmission systems

### Standard

- ◆ Compatible with SFP MSA
- ◆ Compatible with IEEE 802.3ah-2004

### Description



The SFP transceiver is high performance, cost effective modules. It is designed for 100BASE-LX applications of 10km with SMF. The transceiver consists of two sections: The standard SFP part and the PHY part built with SGMII interface.

The optical output can be disabled by a TTL logic high-level input of Tx Disable, and the system also can disable the module via I2C. Tx Fault is provided to indicate that degradation of the laser. Loss of signal (LOS) output is provided to indicate the loss of an input optical signal of receiver or the link status with partner. The system can also get the LOS(or Link)/Disable/Fault information via I2C register access. The standard serial ID information Compatible with SFP MSA describes the transceiver's capabilities, standard interfaces, manufacturer and other information. The host equipment can access this information via the 2-wire serial CMOS EEPROM protocol. For further information, please refer to SFP Multi-Source Agreement (MSA).

### Absolute Maximum Ratings

Stress in excess of the maximum absolute ratings can cause permanent damage to the module

Parameter	Symbol	Min	Max	Unit
Maximum Supply Voltage	Vcc	-0.5	3.6	V
Storage Temperature	TS	-40	85	°C
Relative Humidity	RH	5	85	%

### Recommended Operating Conditions

Parameter	Symbol	Min	Typical	Max	Unit
Operating Case Temperature	TC	0		70	°C
Power Supply Voltage	VCC	3.1	3.3	3.5	V
Power Supply Current	Icc			420	mA
Data Rate			125		Mbps

### Optical and Electrical Characteristics

Parameter	Symbol	Min.	Typical	Max.	Unit	Notes
<b>Transmitter</b>						

Centre Wavelength	$\lambda$ C	1261	1310	1360	nm	
Average Output Power	P0out	-15		-8	dBm	1
Spectral Width (RMS)	$\sigma$			7.7	nm	1
Extinction Ratio	EX	9		17	dB	
Rise/Fall Time	Tr/Tf			3	ns	2
Output Optical Eye	Compatible with IEEE 802.3ah-2004					3
Data Input Swing Differential (SGMII Series interface)	VIN	200		2100	mV	4
Input Differential Impedance	ZIN	80	100	120	$\Omega$	
TX Disable	Disable	2.0		Vcc	V	
	Enable	0		0.8	V	
TX Fault	Fault	2.0		Vcc+0.3	V	
	Normal	0		0.8	V	
<b>Receiver</b>						
Centre Wavelength	$\lambda$ C	1260		1570	nm	
Receiver Sensitivity				-31	dBm	5
Receiver Overload		-8			dBm	5
LOS De-Assert	LOSD			-32.5	dBm	
LOS Assert	LOSA	-45			dBm	
LOS Hysteresis		1		4.5	dB	
Total Jitter (SGMII Series Interface)	Tj			0.43	UI	
Data Output Swing Differential	VOUT	370		2000	mV	4
LOS	High	2.0		Vcc+0.3	V	
	Low	0		0.8	V	

Notes:

1. The optical power is launched into SMF 9/125um.
2. Unfiltered, measured with 4B/5B code for 125Mbps
3. Measured with 4B/5B code for 125Mbps.
4. PECL logic, internally AC coupled.
5. Measured with 4B/5B code for 125Mbps, worst-case extinction ratio, BER  $\leq 1 \times 10^{-10}$

## Diagnostics

Parameter	Range	Unit	Accuracy	Calibration
Temperature	0 to 70	$^{\circ}$ C	$\pm 3^{\circ}$ C	Internal / External
Voltage	0 to VCC	V	$\pm 3\%$	Internal / External
Bias Current	0 to 100	mA	$\pm 10\%$	Internal / External

TX Power	-15 to -8	dBm	±3 dB	Internal / External
RX Power	-33to -12	dBm	±3 dB	Internal / External

## EEPROM Section

The optical transceiver contains an EEPROM. It provides access to sophisticated identification information that describes the transceiver's capabilities, standard interfaces, manufacturer, and other information.

The serial interface uses the 2-wire serial CMOS EEPROM protocol defined for the MCU family of components. When the serial protocol is activated, the host generates the serial clock signal (SCL, Mod Def 1). The positive edge clocks data into those segments of the EEPROM that are not write-protected within the SFP transceiver. The negative edge clocks data from the SFP transceiver. The serial data signal (SDA, Mod Def 2) is bi-directional for serial data transfer. The host uses SDA in conjunction with SCL to mark the start and end of serial protocol activation. The memories are organized as a series of 8-bit data words that can be addressed individually or sequentially.

The Module provides diagnostic information about the present operating conditions. The transceiver generates this diagnostic data by digitization of internal analog signals. Calibration and alarm/warning threshold data is written during device manufacture. Received power monitoring, transmitted power monitoring, bias current monitoring, supply voltage monitoring and temperature monitoring all are implemented. The diagnostic data are raw A/D values and must be converted to real world units using calibration constants stored in EEPROM locations 56 – 95 at wire serial bus address A2h. The digital diagnostic memory map specific data field define as following.

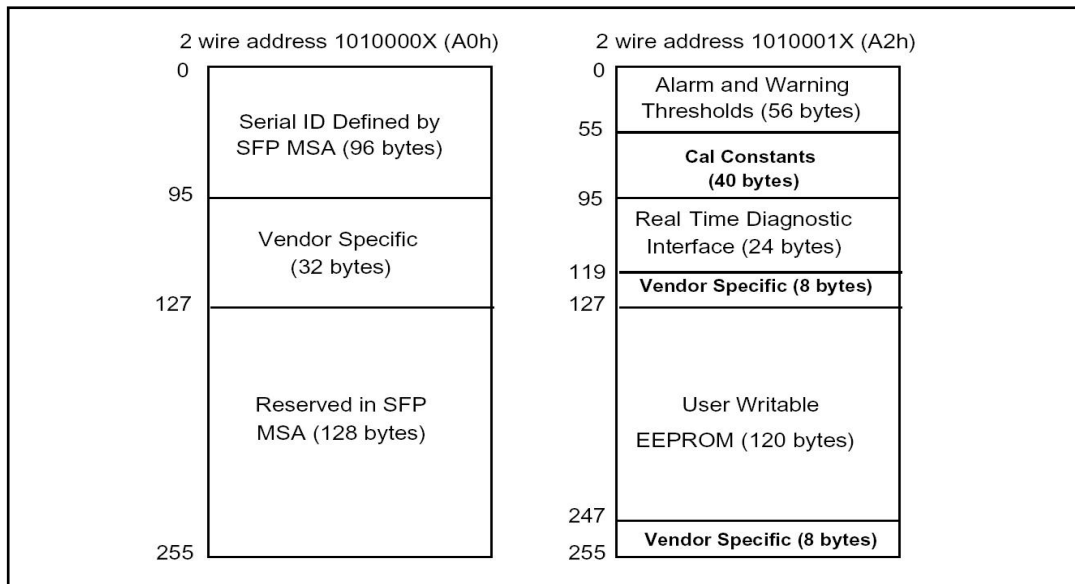

## Pin Definitions

### Pin Diagram

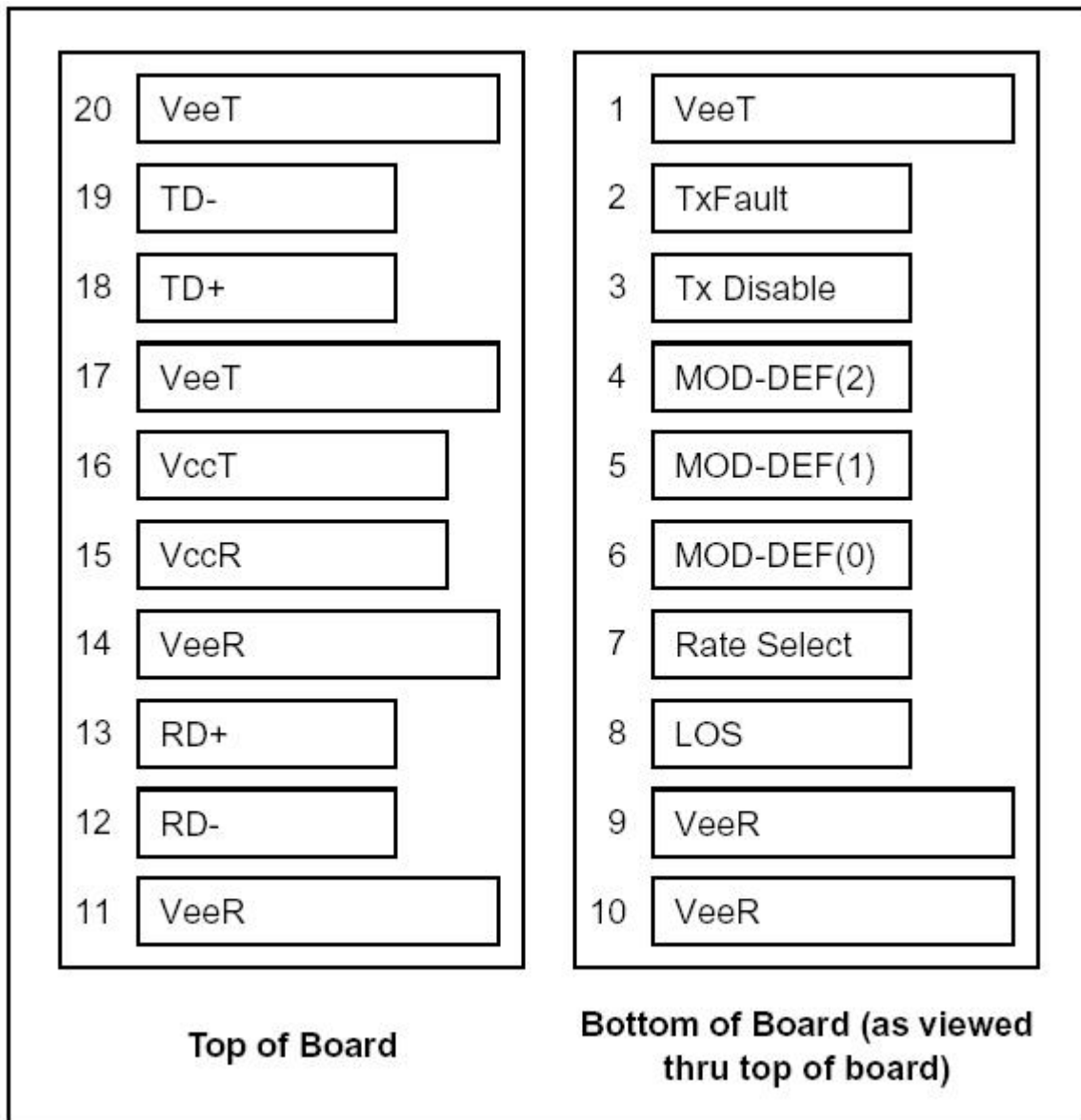

### Pin Descriptions

Pin	Signal Name	Description	Plug Seq.	Notes
1	V <sub>EET</sub>	Transmitter Ground	1	
2	TX FAULT	Transmitter Fault Indication	3	Note1
3	TX DISABLE	Transmitter Disable	3	Note2
4	MOD_DEF(2)	SDA Serial Data Signal	3	Note3

5	MOD_DEF(1)	SCL Serial Clock Signal	3	Note3
6	MOD_DEF(0)	TTL Low	3	Note3
7	Rate Select	Not Connected	3	
8	LOS	Loss of Signal	3	Note 4
9	V <sub>EER</sub>	Receiver ground	1	
10	V <sub>EER</sub>	Receiver ground	1	
11	V <sub>EER</sub>	Receiver ground	1	
12	RX-	Inv. Received Data Out	3	Note 5
13	RX+	Received Data Out	3	Note 5
14	V <sub>EER</sub>	Receiver ground	1	
15	V <sub>CCR</sub>	Receiver Power Supply	2	
16	V <sub>CCT</sub>	Transmitter Power Supply	2	
17	V <sub>EET</sub>	Transmitter Ground	1	
18	TX+	Transmit Data In	3	Note 6
19	TX-	Inv. Transmit Data In	3	Note 6
20	V <sub>EET</sub>	Transmitter Ground	1	

**Notes:**

Plug Seq.: Pin engagement sequence during hot plugging.

- 1) TX Fault is an open collector output, which should be pulled up with a 4.7k~10kΩ resistor on the host board to a voltage between 2.0V and V<sub>cc</sub>+0.3V. Logic 0 indicates normal operation; Logic 1 indicates a laser fault of some kind. In the low state, the output will be pulled to less than 0.8V.
- 2) TX Disable is an input that is used to shut down the transmitter optical output. It is pulled up within the module with a 4.7k~10kΩ resistor. Its states are:
  - Low (0 to 0.8V): Transmitter on
  - (>0.8V, < 2.0V): Undefined
  - High (2.0 to 3.465V): Transmitter Disabled
  - Open: Transmitter Disabled
- 3) Mod-Def 0,1,2. These are the module definition pins. They should be pulled up with a 4.7k~10kΩ resistor on the host board. The pull-up voltage shall be V<sub>ccT</sub> or V<sub>ccR</sub>.
  - Mod-Def 0 is grounded by the module to indicate that the module is present
  - Mod-Def 1 is the clock line of two wire serial interface for serial ID
  - Mod-Def 2 is the data line of two wire serial interface for serial ID
- 4) LOS is an open collector output, which should be pulled up with a 4.7k~10kΩ resistor. Pull up voltage between 2.0V and V<sub>cc</sub>+0.3V. Logic 1 indicates loss of signal; Logic 0 indicates normal operation. In the low state, the output will be pulled to less than 0.8V.
- 5) RD-/+ : These are the differential receiver outputs. They are internally AC-coupled 100 differential lines which should be terminated with 100Ω (differential) at the user SERDES.
- 6) TD-/+ : These are the differential transmitter inputs. They are internally AC-coupled, differential lines with 100Ω differential termination inside the module.

## Mechanical Dimensions

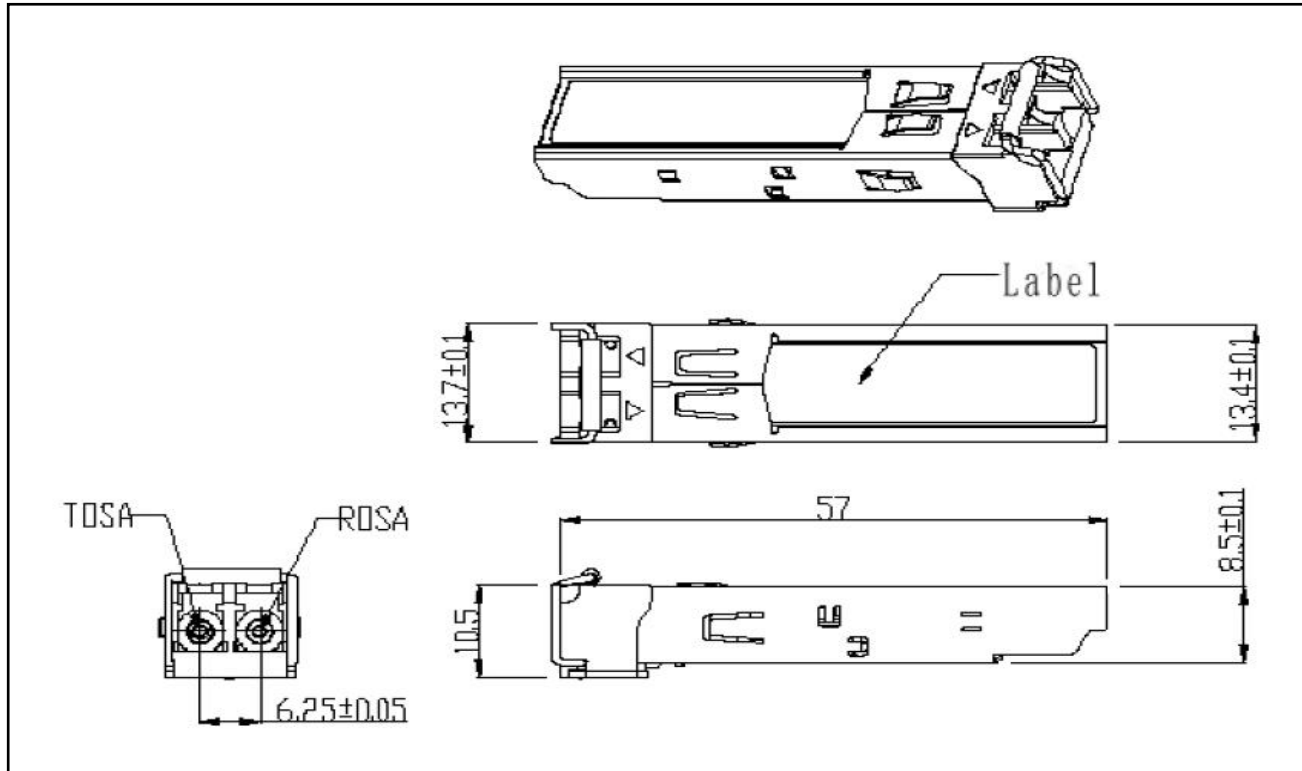

## Regulatory Compliance

GIGALIGHT SFP-SGMII transceiver is designed to be Class I Laser safety compliant and is certified per the following standards:

Feature	Agency	Standard	Certificate / Comments
Laser Safety	FDA	CDRH 21 CFR 1040 and Laser Notice No. 50	1120295-000
Product Safety	BST CCIC	EN 60825-1: 2007 EN 60825-2: 2004 EN 60950-1: 2006 EN55022: 2006 EN61000-3-2: 2006 EN61000-3-3: 1995+A1: 2001+A2: 2005 EN55022: 2006+A1: 2007 EN55024: 1998+A1: 2001+A2: 2003	CE-LVD CE-EMI CE-EMC
Environmental protection	SGS	RoHS Directive 2002/95/EC	GZ0902007478/CHEM
EMC	WALTEK	EN 55022:2006+A1:2007 EN 55024:1998+A1+A2:2003 -	WT10093768-D-E-E

## Ordering information

Part Number	Product Description
-------------	---------------------



GPH-3102-L1C	1310nm,10km,125Mbps, 0°C ~ +70°C
GPH-3102-L1CD	1310nm,10km,125Mbps, 0°C ~ +70°C, With Digital Diagnostic Monitoring

## References

1. Small Form Factor Pluggable (SFP) Transceiver Multi-Source Agreement (MSA),September 2000.
2. IEEE 802.3ah-2004.

## Important Notice

Performance figures, data and any illustrative material provided in this data sheet are typical and must be specifically confirmed in writing by GIGALIGHT before they become applicable to any particular order or contract. In accordance with the GIGALIGHT policy of continuous improvement specifications may change without notice.

The publication of information in this data sheet does not imply freedom from patent or other protective rights of GIGALIGHT or others. Further details are available from any GIGALIGHT sales representative.

E-mail: [sales@gigalight.com.cn](mailto:sales@gigalight.com.cn)

Web : <http://www.gigalight.com.cn>