

50GHz Full C-band Tunable 10GBASE-ZR/OC-192 10Gb/s SFP+ 80km P/N : GPU-CXXX-08CD

Features

- Hot-pluggable SFP+ footprint
- 50GHz DWDM ITU-T Full C-band Tunability
- Support 9.95Gb/s to 11.3Gb/s bit rates
- 80km 50GHz DWDM laser
- 80km APD photodiode receiver
- Single 3.3V power supply
- Power dissipation <1.7W
- -5°C to +70°C
- Duplex LC fiber connectors
- 10GBASE-ZR/ZW
- SDH STM-64ITU-T G.959.1 P1L1-2D2
- Full Digital Optical Monitoring
- Metal enclosure for lower EMI
- Complies with RoHS directive (2002/95/EC)
- Compliant with SFP+ Electrical MSA SFF-8431
- Compliant with SFP+ Mechanical MSA SFF-8432
- Laser Class 1 IEC/CDRH compliant



Applications

- Full C-band Tunable 10GBASE-ZR 10GEthernet
- 8GB/10GB Fibre Channel
- SONET OC-192 LR-2
- SDH STM-64ITU-T G.959.1 P1L1-2D2
- Access DWDM Ethernet Switch or IP Router Interconnect

Descriptions

Gigalight 50GHz Full C-band Tunable SFP+ transceivers are designed for use in 9.95Gb/s to 11.3Gb/s 50GHz DWDM links up to 80km of G.652 fiber. The SFP+ module supports 10GBASE-ZR and -ZW applications along with SONET OC-192 LR-2 and SDH STM-64 ITU-T G.959.1 P1L1-2D2 applications for Ethernet Switches, IP Routers or SONET/SDH optical interfaces. Digital Optical Monitoring interfaces are provided via the SFP+ standards compliant I2C interface.

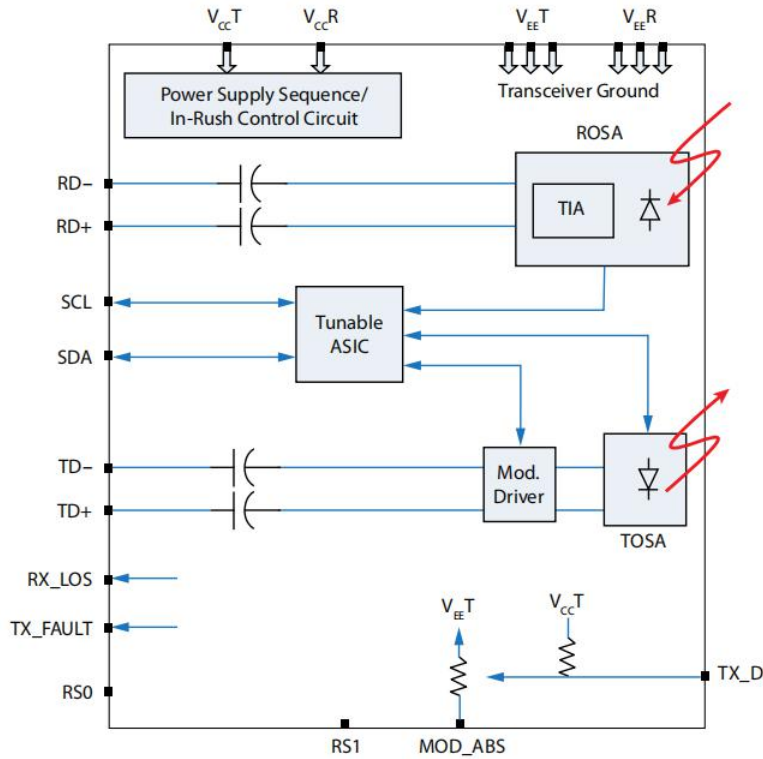

Figure 1. Tunable SFP+ optical transceiver functional block diagram

Transmitter

The transmitter path converts serial NRZ electrical data from 9.95 to 11.3 Gbps line rates to a standard compliant optical signal.

Inside the module, the differential signal is coupled into the modulator driver which transforms the small swing voltage to an output modulation that drives a cooled InP Integrated Laser Mach-Zehnder (ILMZ) modulator. The optical signal is engineered to meet the 10 Gigabit Ethernet, 10 G FC, and corresponding FEC-rates and DWDM specifications at ITU grids with 50 GHz channel spacing. Closed-loop control of the transmitted laser power and modulation swing over temperature and voltage variations are provided. The laser is coupled to a single-mode optical fiber through an industry-standard LC optical connector.

Receiver

The receiver converts incoming DC-balanced serial NRZ 9.95 to 11.3 Gbps line rate optical data into serial SFI electrical data. Light is coupled to an APD from single-mode optical fiber through an industry-standard LC optical connector. The electrical current from the APD is converted to voltage in a limiting trans impedance amplifier.

The amplified signal is output directly on the RD+ and RD- pins as a 100 Ω CML signal.

Low-Speed Signaling

Low-speed signaling is based on low-voltage TTL (LVTTTL) operating at a nominal voltage of 3.3 V. Hosts should use a pull-up resistor connected to VCC

3.3V on the 2-wire interface SCL, SDA, and all low-speed outputs.

Application Schematics

Tunable SFP+ modules are hot pluggable and active connections are powered by individual power connections for the transmitter ($V_{CC T}$) and the receiver ($V_{CC R}$). Multiple modules can share a single 3.3 V power supply with individual filtering for each $V_{CC T}$ and $V_{CC R}$. The host shall generate an effective weighted integrated spectrum RMS noise of less than 25 mV in the 10 Hz to 10 MHz frequency range. Detailed power supply specifications are given in SFF-8431 Rev. 4.1 Section 2.8. Figure 2 shows a typical application schematic.

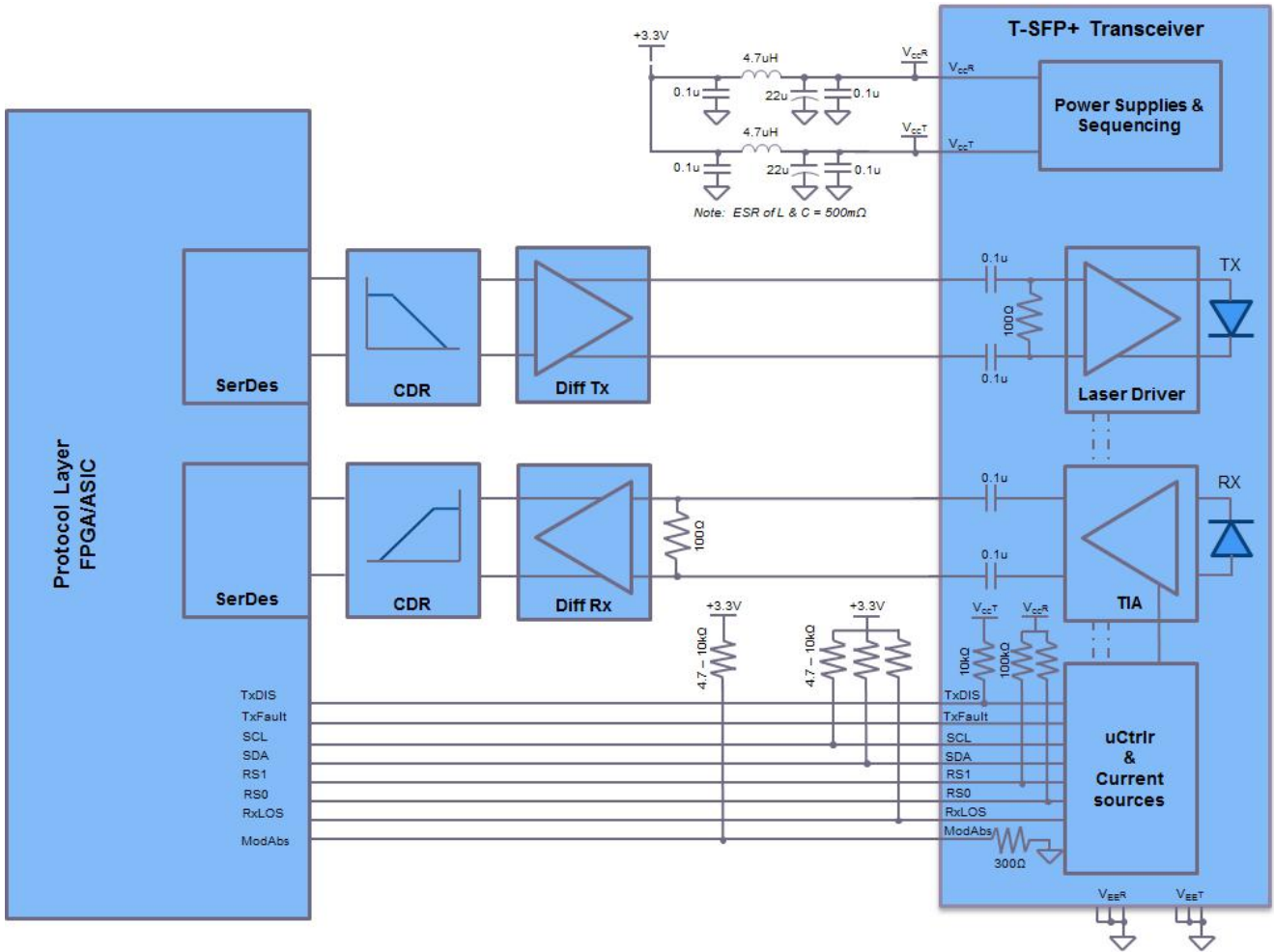

Figure 2. Typical application schematic

Pin Function Definitions

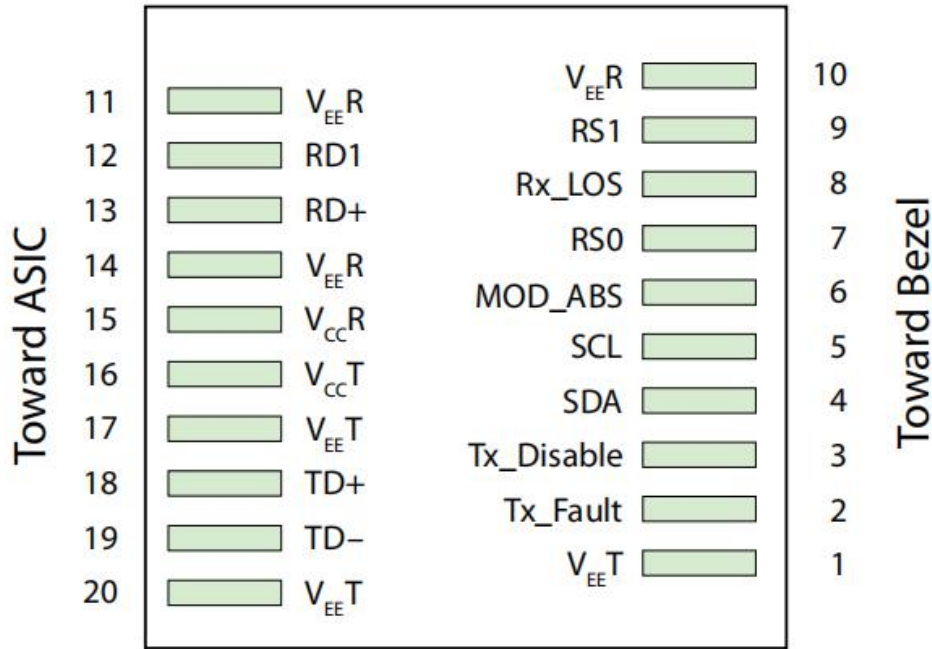

Figure 3. Tunable SFP+ optical transceiver host board pin assignments

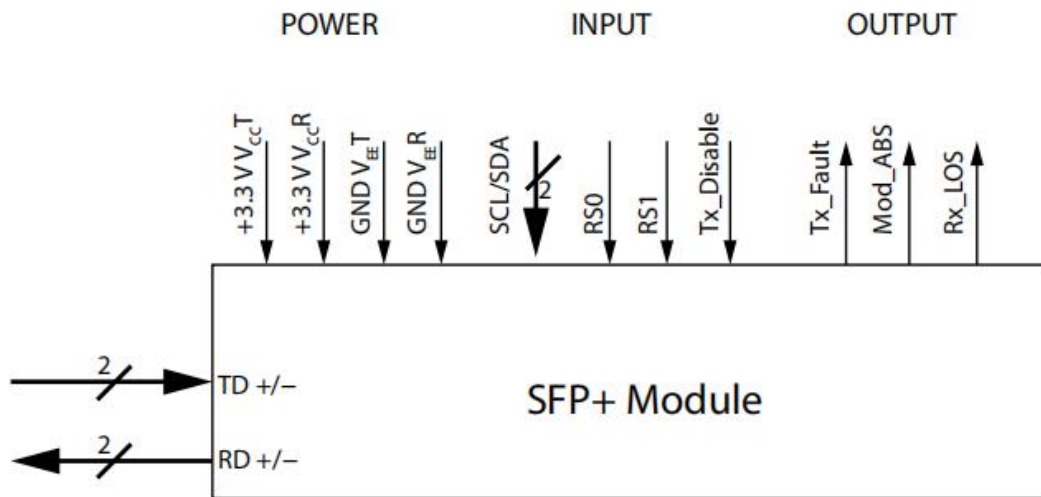

Figure 4. Tunable SFP+ optical transceiver functional schematic

Table 1. SFP+ optical transceiver pin descriptions

Pin No.	Type	Name	Description
1		VEET ¹	Module transmitter ground
2	LVTTL-O	Tx_Fault	Module transmitter fault; when asserted high, it indicates that the module has detected a transmitter fault condition related to laser operation or safety.
3	LVTTL-I	Tx_Disable	Transmitter disable; when asserted high or left open, transmitter laser source turned off; when Tx_Disable is asserted low or grounded, the module transmitter is operating normally.
4	LVTTL-I/O	SDA ²	2-wire interface data line
5	LVTTL-I	SCL ²	2-wire interface clock
6		Mod_ABS ²	Indicates module is not present. Grounded to VEET or VEER in the module. Asserted high when SFP+ module is absent and pulled low when the SFP+ module is inserted.
7	LVTTL-I	RS0 ³	Rate select 0 (not used)
8	LVTTL-O	Rx_LOS ²	Receiver loss of signal indicator. Asserted high when receiving insufficient optical power for reliable signal reception.
9	LVTTL-I	RS1 ³	Rate select 1 (not used)
10		VEER ¹	Module receiver ground
11		VEER ¹	Module receiver ground
12	CML-O	RD-	Receiver inverted data output
13	CML-O	RD+	Receiver non-inverted data output
14		VEER ¹	Module receiver ground
15		VCCR	Module receiver +3.3 V supply
16		VCCT	Module transmitter +3.3 V supply
17		VEET ¹	Module transmitter ground
18	CML-I	TD+	Transmitter non-inverted data input
19	CML-I	TD-	Transmitter inverted data input
20		VEET ¹	Module transmitter ground

1. Module ground pins (GND) are isolated from the module case and chassis ground within the module

2. Shall be pulled up with 4.7 to 10 kΩ to a voltage between 3.135 and 3.465 V on the host board

3. Pulled high to VCCT with >100 kΩ in the module

SFP+ SFI Reference Model Compliance Points

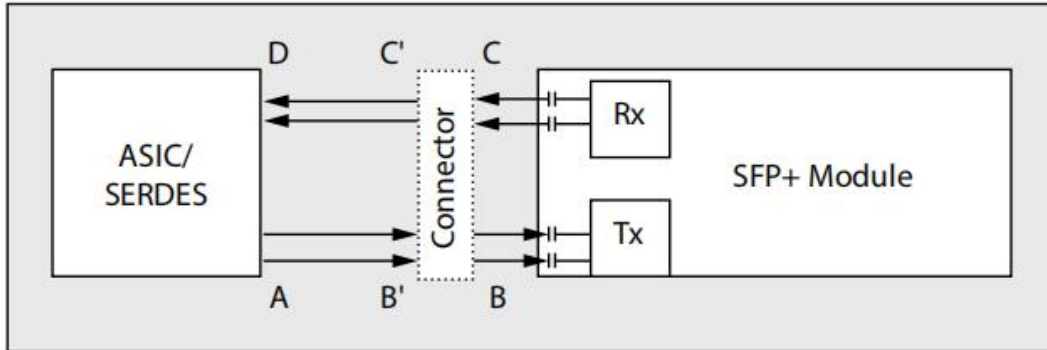

Absolute Maximum Ratings

Absolute maximum ratings represent the device's damage thresholds. Permanent damage may occur if the device is stressed beyond the limits stated here.

Parameter	Symbol	Ratings	Unit
Storage temperature	T_{ST}	-40 to +85	°C
Relative humidity	RH	5 to 85 (noncondensing)	%
Static electrical discharge (human body model)	ESD	200	V
Power supply voltages	V_{CCT} , V_{CCR}	-0.3 to 4.0	V
Receive input optical power (damage threshold)	P_{dth}	+4	dBm

Operating Conditions

Operating conditions establish the range over which the electrical and optical specifications are defined, unless otherwise noted. Performance is not guaranteed for operation at any condition outside the operating limits indicated in this section, except as otherwise noted.

Parameter	Symbol	Min	Max	Unit
Operating case temperature	T_{OP}	-5	+70	°C
Power supply voltages	V_{CCT} , V_{CCR}	3.13 5	3.465	V
Receiver wavelength range	λ	1528 .38	1568.77	nm

Low-Speed Electrical and Power Characteristics

Parameter	Symbol	Min.	Typ.	Max.	Unit	Notes
<i>Supply Currents and Voltages</i>						
Voltage	V_{CCT} , V_{CCR}	3.13 5	3.3	3.465	V	With respect to GND
Instantaneous operating peak current				600	mA	Per supply pin V_{CCT} and V_{CCR} Compliant with SFF-8431

Sustained operating peak current				500	mA	Per supply pin V _{CC} T and V _{CC} R Compliant with SFF-8431
Power dissipation	P _{wr}			1.65	W	

Low-Speed Control and Sense Signals (detailed specification in SFP+ MSASFF-8431 Rev. 4.1)

Outputs (Tx_Fault, Rx_LOS)	V _{OL}	-0.3		0.4	V	At 0.7 mA
	I _{OH}	-50		37.5	μA	Measured with a 4.7 kΩ load pulled up to V _{CC} host ¹
Inputs (Tx_Disable, RS0, RS1)	V _{IL}	-0.3		0.8	V	Pulled up in module to V _{CC} T
	V _{IH}	2		V _{CC} 3+0.3	V	
SCL and SDA inputs	V _{IL}	-0.3		V _{CC} 3*0.3	V	
	V _{IH}	V _{CC} 3*0.7		V _{CC} 3+0.5	V	Pulled up on host to V _{CC} _host ¹ (typical 4.7 – 10 kΩ)

1. V_{CC}_host (min) 3.135 V – (max) 3.465 V

High-Speed Electrical Specifications

Parameter	Symbol	Min.	Typ.	Max.	Unit	Notes
<i>Transmitter Electrical Input Jitter from Hostat B' (detailed specification in SFP+ MSASFF-8431 Rev. 4.1)</i>						
Data-dependent jitter ¹	DDJ			0.10	UI(p-p)	
Uncorrelated jitter ²	UJ			0.023	UI(rms)	
Data-dependent pulse width shrinkage jitter ¹	DDP WS			0.055	UI(p-p)	
Total jitter ³	TJ			0.28	UI(p-p)	
Eye mask	X1			0.12	UI	Mask hit ratio of 5×10^{-5}
	X2			0.33	UI	
	Y1	95			mV	
	Y2			350	mV	
Input impedance, differential			100		Ω	

Limiting Module Receiver Electrical Output Jitter to Hostat C' (detailed specification in SFP+ MSASFF 8431 Rev. 4.1)

Output rise and fall time (20% to 80%)	T_r, T_f	28			ps	
Total jitter ³	TJ			0.70	UI	
99% jitter ³	J2			0.42	UI	
Eye mask	X1			0.35	UI	Rx input power at -23 dBm Mask hit ratio of 1×10^{-12}
	Y1	70			mV	
	Y2			425	mV	

Optical Transmitter Characteristics

Parameter	Symbol	Min.	Typ.	Max.	Unit	Notes
Average optical power ⁴	P_{avg}	-1		3	dBm	
Extinction ratio ⁵	ER	9.0			dB	
Wavelength range ⁴	λ_c	1528. 38		1568. 77	nm	ITU Grid wavelength in Sec. 3.14
Frequency range	f_c	191.1		196.1 5	THz	ITU Grid frequency in Sec. 3.14
Frequency center spacing			50		GHz	
Frequency stability (BOL)		$f_c - 1$		f_c	GHz	

		.5		+1.5		
Frequency stability (EOL)		$f_c - 2$.5		f_c +2.5	GHz	
Channel tuning time				50	ms	Any channel to any channel
Side mode suppression ratio	SMSR	35			dB	
Jitter generation	4 MHz to 80 MHz			0.1	UI (p-p)	
	20 kHz to 80 MHz			0.3	UI(p-p)	
Spectral width				200	pm	At -20 dB, 0.01 nm RBW
Relative intensity noise	RIN			-130	dB/Hz	
Return loss ⁶		24			dB	

1. PRBS9 pattern, 10.3 Gbps
2. PRBS31 or valid 64B/66B, 10.3 Gbps
3. PRBS31 pattern, BER 1×10^{-12}, 10.3 Gbps
4. Optical power and wavelength range are only guaranteed when the electrical input applied to TD+ and TD- is greater than the minimum specified in section 3.6
5. Tested with a PRBS 2³¹-1 pattern
6. Minimum optical return loss at the source reference point, MPI-S (per ITU-T G.959.1)

Optical Receiver Characteristics

Parameter	Symbol	Min.	Typ.	Max.	Unit
Receiver overload ¹	P_{max}	-7			dBm
Receiver reflectance ²	R_{rx}			-27	dB
LOS assert ³	P_{los_on}	-33.5			dBm
LOS deassert	P_{los_off}			-26	dBm
LOS hysteresis		0.5		4	dB
Data Rate (Gbps)	BER	Rx Sensitivity ⁴ 0 ps/nm		Rx Sensitivity ⁴ -400 to +1600 ps/nm	Unit
		Max		Max	
9.95, 10.3, 10.5	1×10^{-12}	-23		-21	dBm
10.709	1×10^{-4}	-27		-25	dBm
11.1	1×10^{-4}	-27		-25	dBm
11.3	1×10^{-4}	-26.5		-24	dBm

OSNR Characteristics with External CDR Implemented on the Host Board⁵

Data Rate (Gbps)	BER	Dispersion (ps/nm)	Rx Power Range (dBm)		OSNR (dB)
			Min	Max	
9.95, 10.3, 10.5	1×10^{-12}	0	-18	-7	24
9.95, 10.3, 10.5	1×10^{-12}	-400 to +1450	-18	-7	26
10.709	1×10^{-4}	0	-18	-7	16
10.709	1×10^{-4}	-400 to +1600	-18	-7	19
11.1	1×10^{-4}	0	-18	-7	17
11.1	1×10^{-4}	-400 to +1600	-18	-7	20

1. Guaranteed up to 10.709 Gbps; BER $< 10^{-12}$; PRBS 2³¹-1
2. Maximum discrete reflectance between source reference point, MPI-S, and receive reference point, MPI-R (per ITU-T G.959.1)
3. Receiver LOS Assert Level (per average power) is programmable upon request
4. Measured with worst ER; PRBS 2³¹-1; over specified wavelength range; OSNR >30 dB; with external clock and data recovery (CDR) board
5. Specifications apply under these conditions:
 - Fixed RxDTV, OSNR at 0.1 nm NBW, 0.55 nm filter BW, PRBS 2³¹-1 pattern, over wavelength range specified in section 3.4
 - External CDR board required for all measurements
 - No threshold adjustment available for optimization

Tunable SFP+ Channel Number and Wavelength

Channel	Frequency (THz)	Center Wavelength (nm)
1	191.10	1568.77
2	191.15	1568.36
3	191.20	1567.95
4	191.25	1567.54
5	191.30	1567.13
6	191.35	1566.72
7	191.40	1566.31
8	191.45	1565.90
9	191.50	1565.50
10	191.55	1565.09
11	191.60	1564.68
12	191.65	1564.27
13	191.70	1563.86
14	191.75	1563.45
15	191.80	1563.05
16	191.85	1562.64
17	191.90	1562.23
18	191.95	1561.83
19	192.00	1561.42
20	192.05	1561.01
21	192.10	1560.61
22	192.15	1560.20
23	192.20	1559.79
24	192.25	1559.39
25	192.30	1558.98
26	192.35	1558.58
27	192.40	1558.17
28	192.45	1557.77
29	192.50	1557.36
30	192.55	1556.96
31	192.60	1556.55
32	192.65	1556.15
33	192.70	1555.75
34	192.75	1555.34
35	192.80	1554.94
36	192.85	1554.54
37	192.90	1554.13
38	192.95	1553.73
39	193.00	1553.33
40	193.05	1552.93
41	193.10	1552.52
42	193.15	1552.12
43	193.20	1551.72
44	193.25	1551.32
45	193.30	1550.92
46	193.35	1550.52
47	193.40	1550.12
48	193.45	1549.72
49	193.50	1549.32
50	193.55	1548.91
51	193.60	1548.51

Channel	Frequency (THz)	Center Wavelength (nm)
52	193.65	1548.11
53	193.70	1547.72
54	193.75	1547.32
55	193.80	1546.92
56	193.85	1546.52
57	193.90	1546.12
58	193.95	1545.72
59	194.00	1545.32
60	194.05	1544.92
61	194.10	1544.53
62	194.15	1544.13
63	194.20	1543.73
64	194.25	1543.33
65	194.30	1542.94
66	194.35	1542.54
67	194.40	1542.14
68	194.45	1541.75
69	194.50	1541.35
70	194.55	1540.95
71	194.60	1540.56
72	194.65	1540.16
73	194.70	1539.77
74	194.75	1539.37
75	194.80	1538.98
76	194.85	1538.58
77	194.90	1538.19
78	194.95	1537.79
79	195.00	1537.40
80	195.05	1537.00
81	195.10	1536.61
82	195.15	1536.22
83	195.20	1535.82
84	195.25	1535.43
85	195.30	1535.04
86	195.35	1534.64
87	195.40	1534.25
88	195.45	1533.86
89	195.50	1533.47
90	195.55	1533.07
91	195.60	1532.68
92	195.65	1532.29
93	195.70	1531.90
94	195.75	1531.51
95	195.80	1531.12
96	195.85	1530.72
97	195.90	1530.33
98	195.95	1529.94
99	196.00	1529.55
100	196.05	1529.16
101	196.10	1528.77
102	196.15	1528.38

SFP+ 2-Wire Interface Protocol and Management Interface

The transceiver incorporates a 2-wire management interface which is used for serial ID, digital diagnostics, and certain control functions. It is modeled on the SFF-8472 Rev 11.3 specification modified to accommodate a single 2-wire interface address. Details of the protocol and interface are explicitly described in the MSA. Please refer to the MSA for design reference.

Digital Diagnostic Monitoring Accuracy

Parameter	Symbol	Max.	Unit	Notes
Transceiver internal temperature	ΔDD M_{T_i} nt	± 3	$^{\circ}C$	
Transceiver internal supply voltage	ΔDD M_{V_i} nt	± 3	%	
Transmitter bias current	ΔDD $M_{I_{bi}}$ as	± 1 0	%	
TX output optical power	ΔDDM $_{PTx}$	± 3	dB	
RX input optical power	ΔDDM $_{PRx}$	± 3	dB	Between Rx overload and sensitivity levels

Timing Requirement of Control and Status I/O

Parameter	Symbol	Min.	Max.	Unit	Notes
Tx_Disable assert time	t_off		10 0	μs	Rising edge of Tx_Disable to fall of output signal below 10% of nominal
Tx_Disable negate time	t_on		50	ms	Falling edge of Tx_Disable to rise of output signal above 90% of nominal ¹
Time to initialize 2-wire interface	t_2w_start _up		30 0	ms	From power on or hot plug
Time to initialize	t_start_up_c ooled		90	s	From power on or hot plug
Tx_Fault assert	Tx_Fault_on _cooled		50	ms	From occurrence of fault to assertion of Tx_Fault
Tx_Fault reset	Tx_Fault_r	10		μs	Time Tx_Disable must

	eset				be held high to reset Tx Fault
Rx_LOS assert delay	t_loss_on		100	μs	From occurrence of loss of signal to assertion of Rx_LOS
RX_LOS negate delay	t_loss_off		100	μs	From occurrence of return of signal to negation of RX_LOS

1. The transceiver is thermally stabilized prior to Tx_Disable negating event.

3.14 Timing Diagram for Power-On/Hot-Plug and Tx Disable Event (Not to Scale)

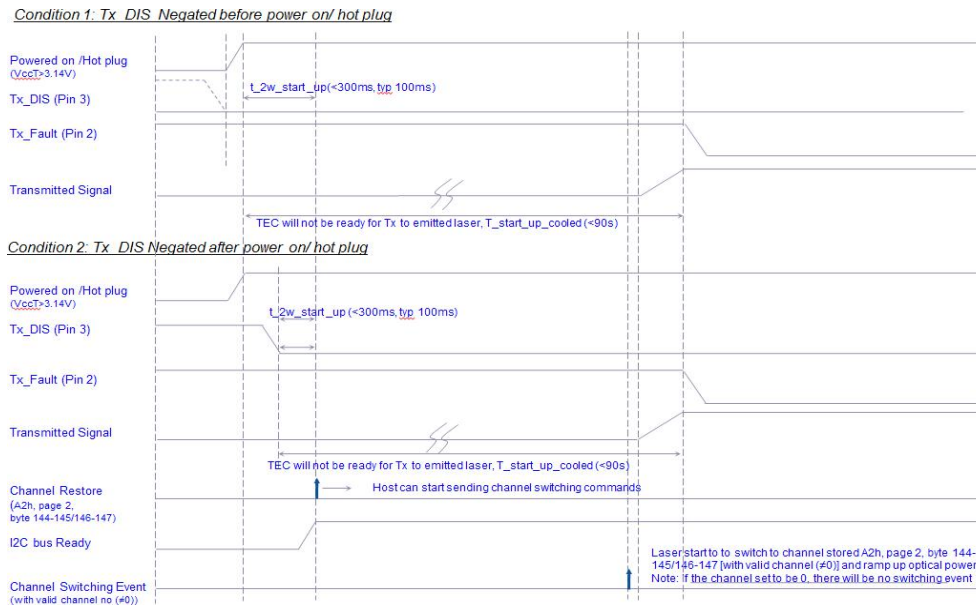

Regulatory Compliance

The transceiver complies with international safety and electromagnetic compatibility (EMC) requirements and standards. EMC performance depends on the overall system design. The transceiver is also lead-free and RoHS 6/6 compliant.

Table 2. Regulatory Compliance

Feature	Test Method	Performance
Safety		
Product	UL 60950-1	UL recognized component for US and CAN
	CSA C22.2 No. 60950-1	
	EN 60950-1	TUV certificate
	IEC 60950-1	CB certificate
	Flame Class V-0	Passes needle point flame test for component flammability verification
	Low Voltage Directive 2006/95/EC	Certified to harmonized standards listed; Declaration of Conformity issued
Laser	EN 60825-1, EN 60825-2	TUV certificate
	IEC 60825-1	CB certificate
	U.S. 21 CFR 1040.10	FDA/CDRH certified with accession number
Electromagnetic Compatibility		
Radiated emissions	EMC Directive 2004/108/EC	Class B digital device with a minimum –6 dB margin to the limit. Final margin may vary depending on system implementation.
	FCC rules 47 CFR Part 15	
	CISPR 22	
	AS/NZS CISPR22	Tested frequency range: 30 MHz to 40 GHz or 5th harmonic (5 times the highest frequency), whichever is less.
	EN 55022	
	ICES-003, Issue 5	Requires good system EMI design practice to achieve Class B margins at the system level.
	VCCI-3	
Immunity	EMC Directive 2004/108/EC	Certified to harmonized standards listed; Declaration of Conformity issued.
	CISPR 24	
	EN 55024	
ESD	IEC/EN 61000-4-2	Exceeds requirements. Withstands discharges of ± 8 k V contact, ± 15 k V air.
Radiated immunity	IEC/EN 61000-4-3	Exceeds requirements. Field strength of 10 V/m from 10 MHz to 6 GHz. No detectable effect on transmitter/receiver performance between these limits.

Restriction of Hazardous Substances (RoHS)

RoHS	EU Directive 2011/65/EU	Compliant per the European Parliament Directive 2011/65/EU of the 8 June 2011 on the restricted use of certain hazardous substances in electrical and electronic equipment (recast). A RoHS Certificate of Conformance (C of C) is available upon request. The product may use certain RoHS exemptions.
------	-------------------------	--

T-SFP+ Transceiver Mechanical Diagram

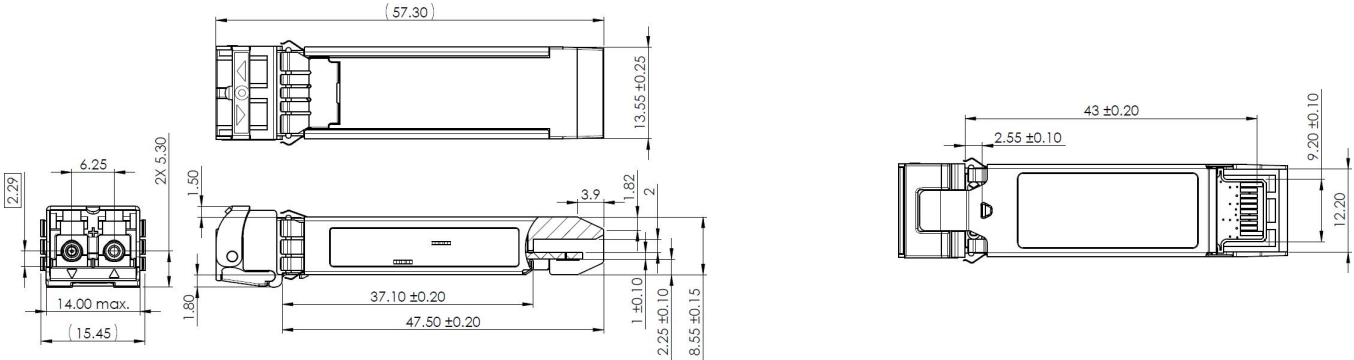

Ordering Information

Part Number	Product Description
GPU-CXXX-08CD	XXX=ITU channel(Gigalight ID), C-band Tunable DWDM SFP+, 80km, 0°C~70°C

Important Notice

Performance figures, data and any illustrative material provided in this data sheet are typical and must be specifically confirmed in writing by GIGALIGHT before they become applicable to any particular order or contract. In accordance with the GIGALIGHT policy of continuous improvement specifications may change without notice. The publication of information in this data sheet does not imply freedom from patent or other protective rights of GIGALIGHT or others. Further details are available from any GIGALIGHT sales representative.

E-mail: sales@gigalight.com.cn

Web: <http://www.gigalight.com.cn>