

## 25G SFP28 ZR 80KM SOA+PIN C-Temp GSS-S8250-ZRC

### Features

- ✓ Hot-pluggable SFP28 form factor
- ✓ Supports 25.78Gb/s aggregate bit rate
- ✓ Transmitter: Cooled 25Gb/s EML 1309nm TOSA
- ✓ Receiver: 25Gb/s SOA + PIN integrated ROSA
- ✓ Internal CDR circuits on both receiver and transmitter channels
- ✓ 2.5W maximum power dissipation
- ✓ Maximum link length of 80Km over SMF
- ✓ Duplex LC receptacle
- ✓ Operating case temperature range: 0 to 70°C
- ✓ Single 3.3V power supply
- ✓ RoHS compliant (2011/65/EU, lead free) 



### Applications

- ✓ CPRI Option 10
- ✓ 25G Ethernet

### Description

This product is a 25G SFP28 transceiver designed for optical communication compliant with 25GE standard, uses a single 1309nm channel to transport a 25G Ethernet signal. Its high performance cooled EML transmitter and high sensitivity SOA receiver provide superior performance for 25GE application up to 80km (with FEC) Links.

The product is designed with SFP28 form factor, which is the optical/electrical connection according to the SFP+ Multi-Source Agreement (MSA).

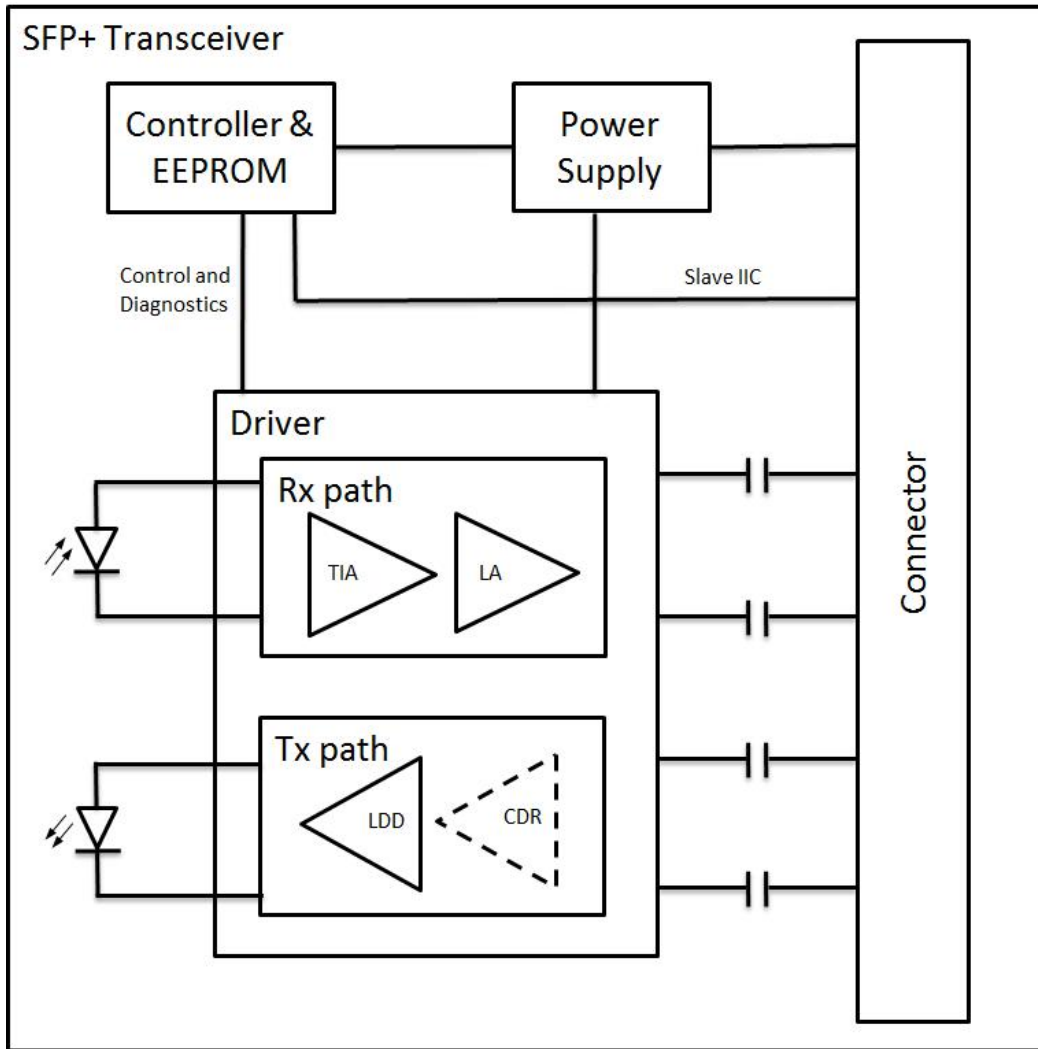

**Figure 1. Module Block Diagram**

The SFP28 is an Enhanced Small Form Factor Pluggable SFP+ transceiver, and can be contacted through I2C system.

### Absolute Maximum Ratings

Parameter	Symbol	Min	Max	Unit
Supply Voltage	$V_{cc}$	-0.3	3.6	V
Input Voltage	$V_{in}$	-0.3	$V_{cc}+0.3$	V
Storage Temperature	$T_s$	-40	85	°C
Case Operating Temperature	$T_c$	0	70	°C
Humidity (non-condensing)	Rh	0	85	%

## Recommended Operating Conditions

Parameter	Symbol	Min	Typical	Max	Unit
Supply Voltage	$V_{CC}$	3.13	3.3	3.47	V
Operating Case Temperature	$T_c$	0		70	°C
Data Rate Per Lane	fd		25.78		Gb/s
Humidity	Rh	0		85	%
Power Dissipation	$P_m$			2.5	W
Link Distance with G.652	D			80	km

## Electrical Specifications

Parameter	Symbol	Min	Typical	Max	Unit
Differential Input Impedance	$Z_{in}$	90	100	110	ohm
Differential Output Impedance	$Z_{out}$	90	100	110	ohm
Differential Input Voltage Amplitude <sup>1</sup>	$\Delta V_{in}$	300		1100	mVp-p
Differential Output Voltage Amplitude <sup>2</sup>	$\Delta V_{out}$	500		800	mVp-p
Skew	Sw			300	ps
Input Logic Level High	$V_{IH}$	2.0		$V_{CC}$	V
Input Logic Level Low	$V_{IL}$	0		0.8	V
Output Logic Level High	$V_{OH}$	$V_{CC}-0.5$		$V_{CC}$	V
Output Logic Level Low	$V_{OL}$	0		0.4	V

### Note:

1. Differential input voltage amplitude is measured between TxnP and TxnN.
2. Differential output voltage amplitude is measured between RxnP and RxnN.

## Optical Characteristics

Parameter	Symbol	Min	Typical	Max	Unit
<b>Transmitter</b>					
Data rate	BR		25.78	-	Gbps
Optical Wavelength	$\lambda_c$	1308.09		1310.14	nm
Side-Mode Suppression Ratio	SMSR	30			dB

Spectral Width (-20dB)	$\Delta\lambda_{20}$	-	-	1	nm
Average Launch Power	$P_{out}$	2		7	dBm
Optical Modulation Amplitude	OMA	3.7		7.8	dBm
Extinction Ratio	ER	8			dB
Average Launch Power of OFF Transmitter	$P_{off}$			-30	dB
$Rin_{20OMA}$				-130	dB/HZ
<b>Receiver</b>					
Data rate	BR		25.78	-	Gbps
Center Wavelength	$\lambda_c$	1308.09		1310.14	nm
Average Receive Power	$P_{avg}$			-5	dBm
Receiver Sensitivity in OMA <sup>1</sup>	RS <sub>oma</sub>			-28	dBm
Receiver Reflectance	$R_R$			-26	dB
LOS Assert	LOS <sub>A</sub>	-40			dBm
LOS De-Assert	LOS <sub>D</sub>			-29	dBm
LOS Hysteresis	LOS <sub>H</sub>	0.5			dB

**Note:**

1. Hit Ratio =  $5 \times 10^{-5}$ . Unstressed receiver OMA sensitivity.

**Pin Description**

Pin	Logic	Symbol	Name/Description	Note
1		VeeT	Module Transmitter Ground	1
2	LVTTL-O	TX_Fault	Module Transmitter Fault	2
3	LVTTL-I	TX_Dis	Transmitter Disable; Turns off transmitter laser output	
4	LVTTL-I/O	SDA	2-Wire Serial Interface Data Line	2
5	LVTTL-I	SCL	2-Wire Serial Interface Clock	2
6		MOD_ABS	Module Definition, Grounded in the module	
7	LVTTL-I	RS0	Receiver Rate Select	
8	LVTTL-O	RX_LOS	Receiver Loss of Signal Indication Active LOW	
9	LVTTL-I	RS1	Transmitter Rate Select (not used)	
10		VeeR	Module Receiver Ground	1
11		VeeR	Module Receiver Ground	1
12	CML-O	RD-	Receiver Inverted Data Output	

13	CML-O	RD+	Receiver Data Output	
14		VeeR	Module Receiver Ground	1
15		VccR	Module Receiver 3.3 V Supply	
16		VccT	Module Receiver 3.3 V Supply	
17		VeeT	Module Transmitter Ground	1
18	CML-I	TD+	Transmitter Non-Inverted Data Input	
19	CML-I	TD-	Transmitter Inverted Data Input	
20		VeeT	Module Transmitter Ground	1

**Note:**

1. Module ground pins GND are isolated from the module case.
2. Shall be pulled up with 4.7K-10Kohms to a voltage between 3.15V and 3.45V on the host board.

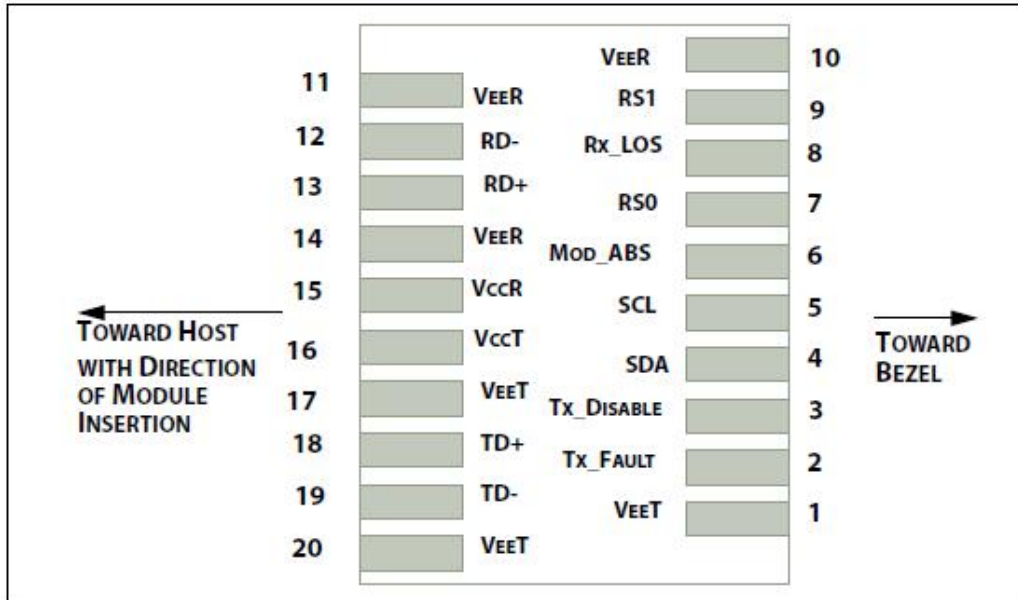

**Figure 2. Electrical Pin-out Details**

**TX\_FAULT Pin**

Tx\_Fault is a module output that when high, indicates that the module transmitter has detected a fault condition related to laser operation or safety. The Tx\_Fault output is an open drain/collector and shall be pulled up to the Vcc\_Host in the host with a resistor in the range 4.7 kΩ to 10 kΩ.

**TX\_DISABLE Pin**

When Tx\_Disable is asserted high or left open, the SFP+ module transmitter output shall be turned off unless the module is a passive cable assembly. This contact shall be pulled up to VccT with a 4.7 kΩ to 10 kΩ resistor in modules and cable assemblies. Tx\_Disable is a module input contact.

**RS0/RS1 Pin**

RS0 and RS1 are module inputs and are pulled low to VeeT with > 30 kΩ resistors in the module. RS0 optionally selects the optical receive signaling rate coverage. RS1 optionally selects the optical transmit signaling rate coverage.

**MOD\_ABS Pin**

Mod\_ABS is connected to VeeT or VeeR in the SFP+ module. The host may pull this contact up to Vcc\_Host with a resistor in the range 4.7 kΩ to 10 kΩ. Mod\_ABS is asserted “High” when the SFP+ module is physically absent from a host slot. In the SFP MSA (INF-8074i) this contact has the same function but is called MOD\_DEF0.

**RX\_LOS Pin**

Rx\_LOS when high indicates an optical signal level below that specified in the relevant standard. Rx\_LOS is an open drain/collector output, but may also be used as an input by supervisory circuitry in the module. For a nominally 3.3 V Vcc\_Host using a resistive pull up to Vcc\_Host the resistor value shall be in the range 4.7 kΩ to 10 kΩ. For a nominally 2.5 V Vcc\_Host using a resistive pull up to Vcc\_Host the resistor value shall be in the range 4.7 kΩ to 7.2 kΩ.

## Recommended Interface Circuit

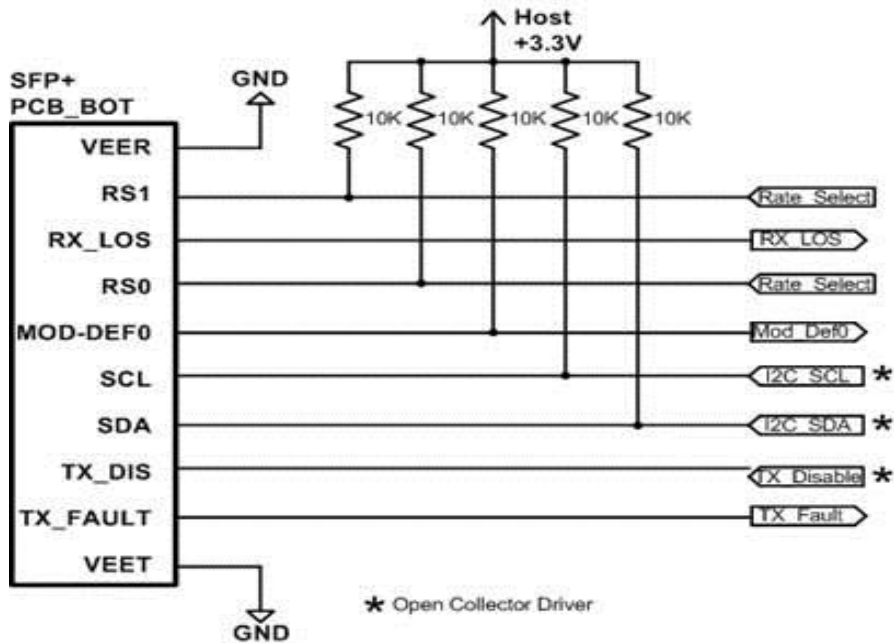
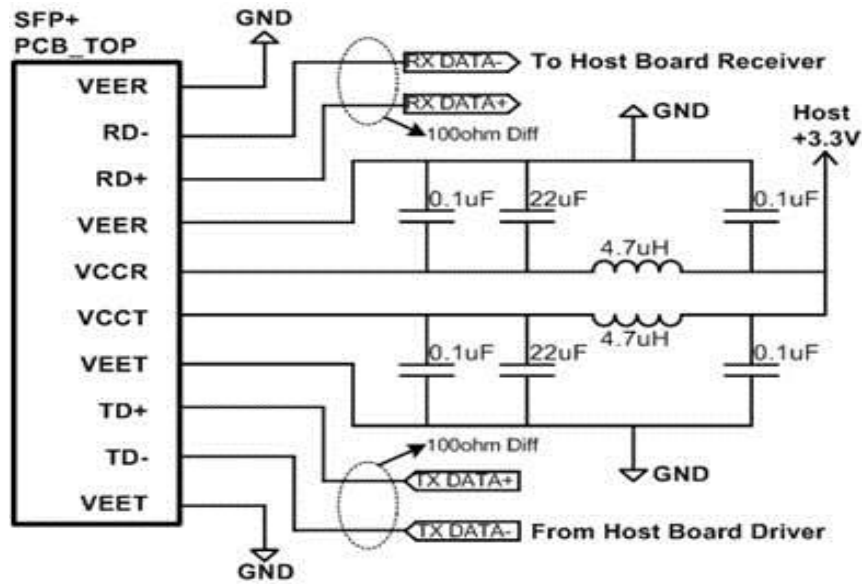
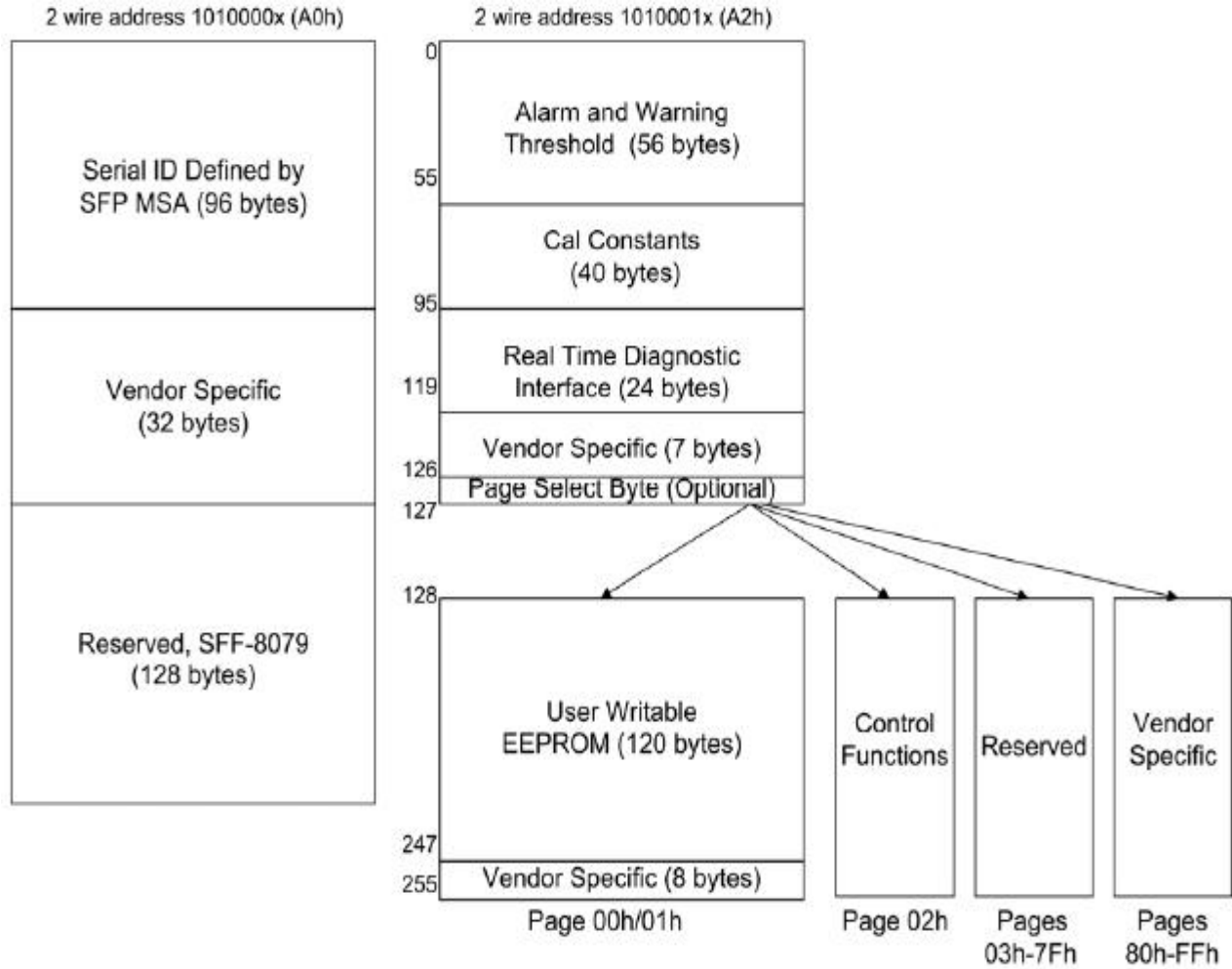

Figure 3.Recommended Interface Circuit

## Memory Organization

The transceivers provide serial ID memory contents and diagnostic information about the present operating conditions by the 2-wire serial interface (SCL, SDA). The memory map specific data field defines as following.



**Figure 4.SFP28 Memory Map**



## Mechanical Dimensions

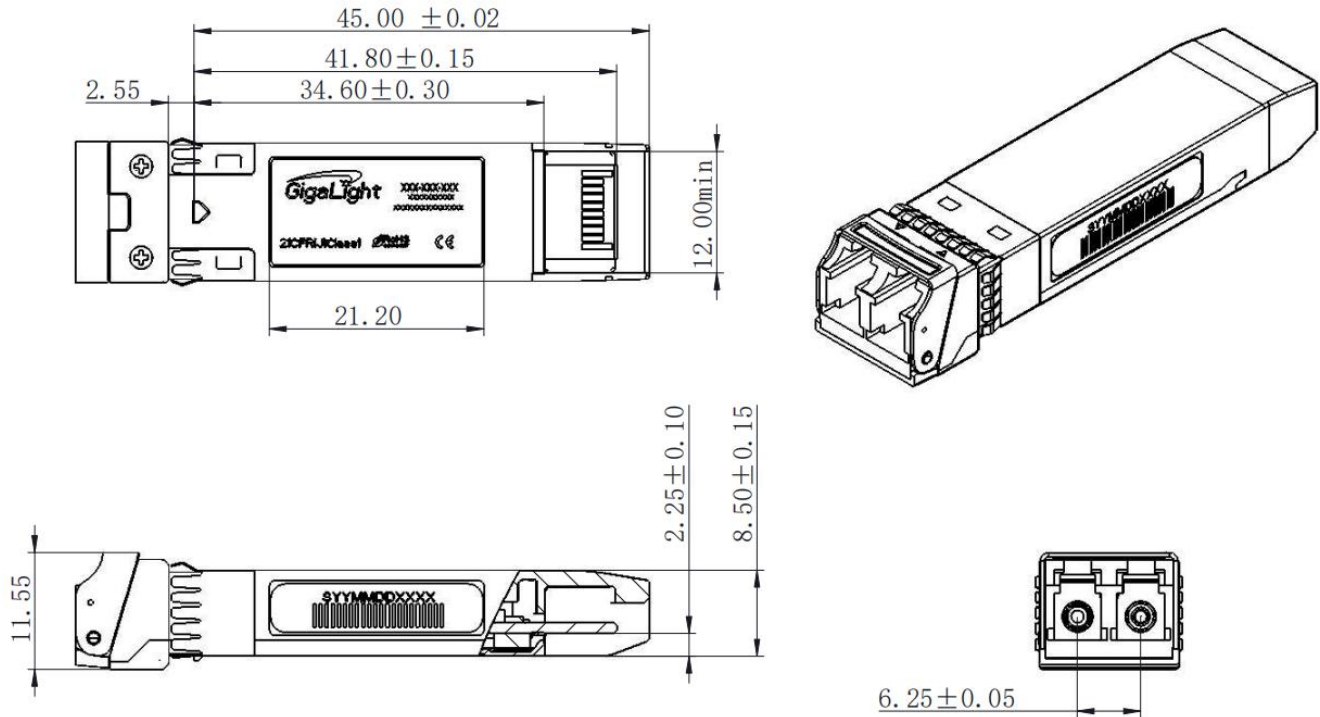

**Figure 5. Mechanical Specifications**

## Regulatory Compliance

GigalightGSS-SPO280-ERT transceivers are Class 1 Laser Products. They meet the requirements of the following standards:

Feature	Standard
Laser Safety	IEC 60825-1:2014 (3 <sup>rd</sup> Edition) IEC 60825-2:2004/AMD2:2010 EN 60825-1:2014 EN 60825-2:2004+A1+A2
Electrical Safety	EN 62368-1: 2014 IEC 62368-1:2014 UL 62368-1:2014
Environmental protection	Directive 2011/65/EU with amendment(EU)2015/863
CE EMC	EN55032: 2015 EN55035: 2017 EN61000-3-2:2014 EN61000-3-3:2013
FCC	FCC Part 15, Subpart B; ANSI C63.4-2014

## References

- 1.SFP28 MSA
- 2.Ethernet IEEE802.3cc
- 3.Directive 2011/65/EU of the European Parliament and of the Council, “on the restriction of the use of certain hazardous substances in electrical and electronic equipment,” July 1, 2011.

## CAUTION:

Use of controls or adjustment or performance of procedures other than those specified herein may result in hazardous radiation exposure.

## Ordering Information

Part Number	Product Description
GSS-S8250-ZRC	1309nm, SFP28, 25G Ethernet ZR, SOA+PIN, 80km,0°C ~ +70°C

## Important Notice

Performance figures,data and any illustrative material provided in this data sheet are typical and must be specifically confirmed in writing by Gigalight before they become applicable to any particular order or contract. In accordance with the Gigalight policy of continuous improvement specifications may change without notice. The publication of information in this data sheet does not imply freedom from patent or other protective rights of Gigalight or others. Further details are available from any Gigalight sales representative.

E-mail: [sales@gigalight.com](mailto:sales@gigalight.com)

Official Site: [www.gigalight.com](http://www.gigalight.com)

## Revision History

Revision	Date	Description
V0	Sep-04-2024	Advance Release.