

Gigalight 100GE QSFP28 Direct Attach Cable

P/N: GQS-PC101-XXC

Features

- ◆ QSFP28 conforms to the Small Form Factor SFF8665
- ◆ 4-Channel Full-Duplex Passive Copper Cable Transceiver
- ◆ Support data rates : 25.78Gb/s (per channel)
- ◆ Maximum aggregate data rate: 100Gb/s (4 x 25.78Gb/s)
- ◆ IEEE 802.3bj 100GBASE-CR4
- ◆ Copper link length up to 5m
- ◆ Power Supply :+3.3V
- ◆ Low crosstalk
- ◆ I2C based two-wire serial interface for EEPROM signature which can be customized
- ◆ Operating Temperature: 0~ 70 °C
- ◆ ROHS Compliant



Applications

- ◆ 100 Gigabit Ethernet
- ◆ Fiber Channel over Ethernet
- ◆ Data storage and communication industry
- ◆ Switch / router / HBA
- ◆ Enterprise network
- ◆ SAN
- ◆ Data Center Network

STANDARDS COMPLIANCE

- ◆ IEEE 802.3bj
- ◆ InfiniBand EDR
- ◆ QSFP28 MSA

- ◆ RoHS Compliant

Product Description

The 100GE QSFP28 cable assemblies are high performance, cost effective I/O solutions for LAN, HPC and SAN. The high speed cable assemblies meet and exceed 100 Gigabit Ethernet, InfiniBand EDR and temperature requirements for performance and reliability. The cables are compliant with SFF-8436 specifications and provide connectivity between devices using QSFP ports.

Recommended Operating Conditions

Parameter	Symbol	Min	Typical	Max	Unit
Storage Ambient Temperature		-40		+85	°C
Operating Case Temperature	T _c	0		+70	°C
Power Supply Voltage	V _{CC3}	3.14	3.3	3.47	V
Data Rate Per Lane		1		25.78	Gb/s

High Speed Characteristics

Parameter	Symbol	Min	Typical	Max	Unit	Note
Differential Impedance(bulk cable)	Rin1,P-P	95	100	110	Ω	
Differential Impedance (Mated connector)	Rin2,P-P	90	100	110	Ω	
Differential Impedance(cable termination)	Rin3,P-P	85	100	110	Ω	
Insertion loss	SDD21			22.48	dB	At 12.8906 GHz
Differential Return Loss	SDD11			See 1	dB	At 0.05 to 4.1 GHz
	SDD22			See 2	dB	At 4.1 to 19 GHz
Common-mode to common-mode output return loss	SCC11	2			dB	At 0.2 to 19 GHz
	SCC22					
Differential to common-mode return loss	SCD11			See 3	dB	At 0.01 to 12.89 GHz
	SCD22			See 4		At 12.89 to 19 GHz
Differential to common Mode Conversion Loss	SCD21			10	dB	At 0.01 to 12.89 GHz
				See 5		At 12.89 to 15.7 GHz
				6.3		At 15.7 to 19 GHz
Channel Operating Margin	COM	3			dB	

Notes:

1. Reflection Coefficient given by equation $SDD11(dB) < 16.5 - 2 \times \text{SQRT}(f)$, with f in GHz
2. Reflection Coefficient given by equation $SDD11(dB) < 10.66 - 14 \times \log_{10}(f/5.5)$, with f in GHz

3. Reflection Coefficient given by equation $SCD_{11}(dB) < 22 - (20/25.78)*f$, with f in GHz
4. Reflection Coefficient given by equation $SCD_{11}(dB) < 15 - (6/25.78)*f$, with f in GHz
5. Reflection Coefficient given by equation $SCD_{21}(dB) < 27 - (29/22)*f$, with f in GHz

Mechanical Dimensions

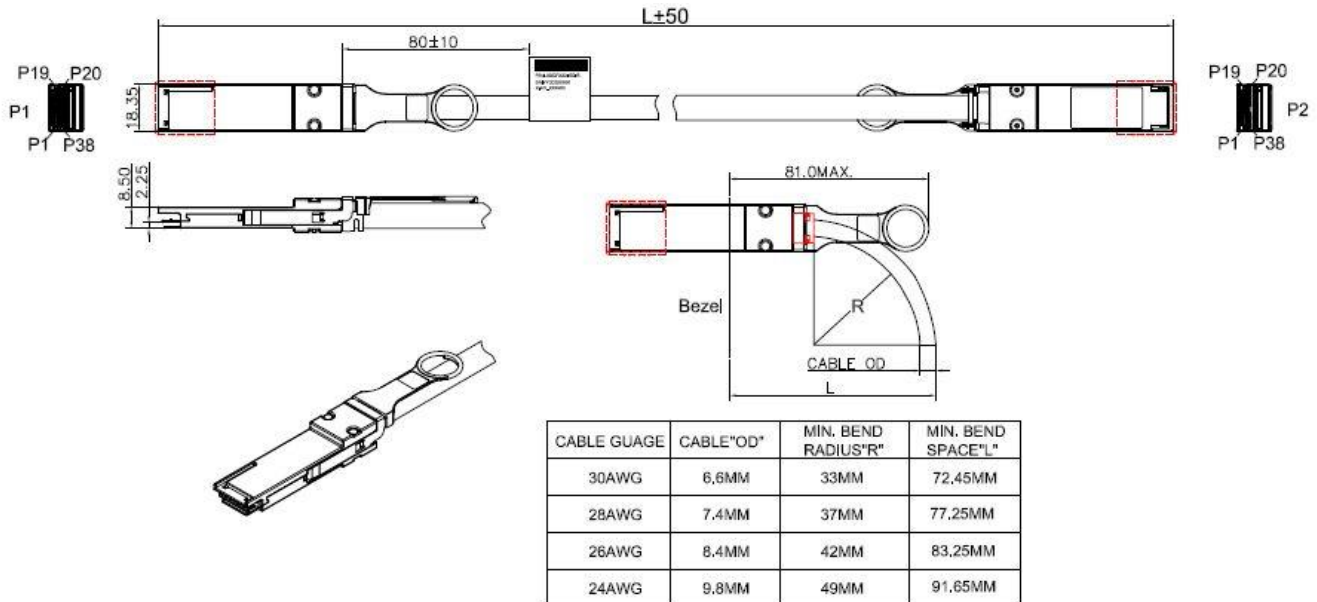

Pin Descriptions

Pin	Logic	Symbol	Name/Description	Notes
1		GND	Ground	1
2	CML-I	Tx2n	Transmitter Inverted Data Input	
3	CML-I	Tx2p	Transmitter Non-Inverted Data Input	
4		GND	Ground	1
5	CML-I	Tx4n	Transmitter Inverted Data Input	
6	CML-I	Tx4p	Transmitter Non-Inverted Data Input	
7		GND	Ground	1
8	LVTTL-I	ModSelL	Module Select	
9	LVTTL-I	ResetL	Module Reset	
10		Vcc Rx	+3.3V Power Supply Receiver	2
11	LVC MOSI/O	SCL	2-wire serial interface clock	
12	LVC MOSI/O	SDA	2-wire serial interface data	
13		GND	Ground	1
14	CML-O	Rx3p	Receiver Non-Inverted Data Output	
15	CML-O	Rx3n	Receiver Inverted Data Output	
16		GND	Ground	1



17	CML-O	Rx1p	Receiver Non-Inverted Data Output	
18	CML-O	Rx1n	Receiver Inverted Data Output	
19		GND	Ground	1
20		GND	Ground	1
21	CML-O	Rx2n	Receiver Inverted Data Output	
22	CML-O	Rx2p	Receiver Non-Inverted Data Output	
23		GND	Ground	1
24	CML-O	Rx4n	Receiver Inverted Data Output	
25	CML-O	Rx4p	Receiver Non-Inverted Data Output	
26		GND	Ground	1
27	LVTTL-O	ModPrsL	Module Present	
28	LVTTL-O	IntL	Interrupt	
29		Vcc Tx	+3.3V Power supply transmitter	2
30		Vcc1	+3.3V Power supply	2
31	LVTTL-I	LPMODE	Low Power Mode	
32		GND	Ground	1
33	CML-I	Tx3p	Transmitter Non-Inverted Data Input	
34	CML-I	Tx3n	Transmitter Inverted Data Input	
35		GND	Ground	1
36	CML-I	Tx1p	Transmitter Non-Inverted Data Input	
37	CML-I	Tx1n	Transmitter Inverted Data Input	
38		GND	Ground	1

Note:

1. GND is the symbol for signal and supply (power) common for the QSFP+ module. All are common within the QSFP+ module and all module voltages are referenced to this potential unless otherwise noted. Connect these directly to the host board signal-common ground plane.
2. Vcc Rx, Vcc1 and Vcc Tx are the receiver and transmitter power supplies and shall be applied concurrently. Requirements defined for the host side of the Host Edge Card Connector are listed in Table 6. Recommended host board power supply filtering is shown in Figure 4. Vcc Rx Vcc1 and Vcc Tx may be internally connected within the QSFP+ Module module in any combination. The connector pins are each rated for a maximum current of 500 mA.

Channel insertion loss budget

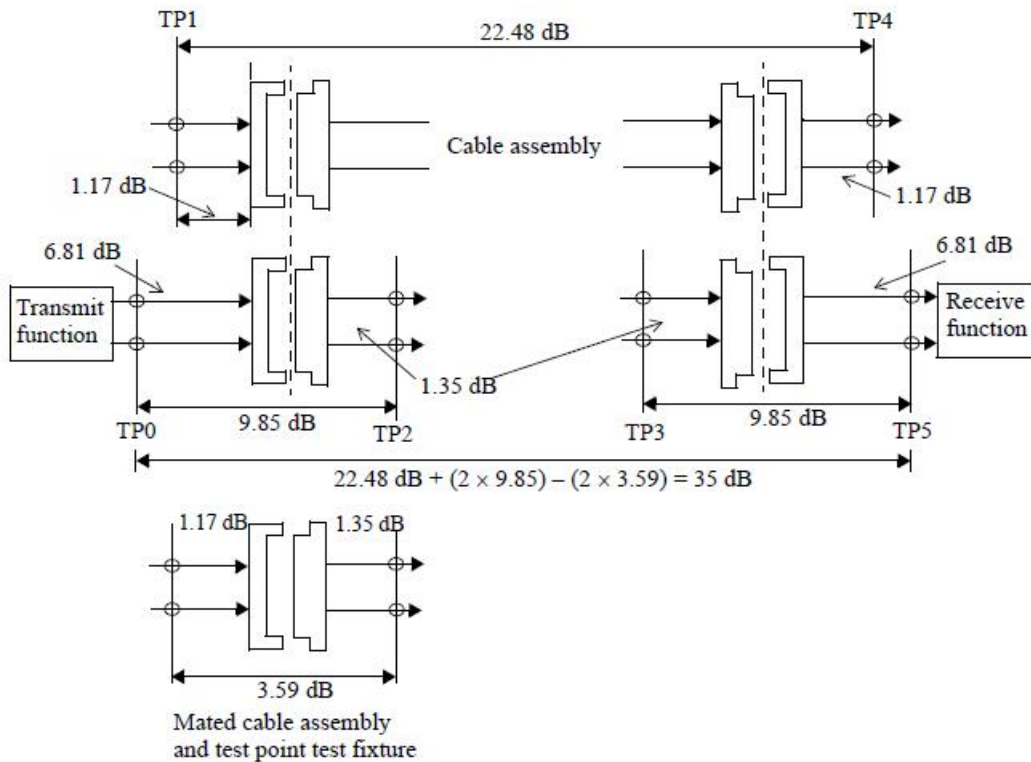

NOTE—The connector insertion loss is 1.07 dB for the mated test fixture. The host connector is allocated 0.62 dB of additional margin.

Figure 92A-2—35 dB channel insertion loss budget at 12.8906 GHz

Ordering information

Part Number	GQS-PC101-XXC				
Length (meter)	1	2	3	4	5
Wire gauge (AWG)	30	30	26/30	26	26

Example:

GQS-PC101-01C/30AWG

GQS-PC101-04C/26AWG

Important Notice

Performance figures, data and any illustrative material provided in this data sheet are typical and must be specifically confirmed in writing by GIGALIGHT before they become applicable to any particular order or contract. In accordance with the GIGALIGHT policy of continuous improvement specifications may change without notice.



The publication of information in this data sheet does not imply freedom from patent or other protective rights of GIGALIGHT or others. Further details are available from any GIGALIGHT sales representative.

sales@gigalight.com.cn
<http://www.gigalight.com>

Revision History

Revision	Date	Description
V0	Jul. 7th, 2017	New release
V1	Mar. 26th,2019	Change copper link length from 'up to 3m' to 'up to 5m'
V2	Apr. 2nd, 2022	Update differential impedance information